

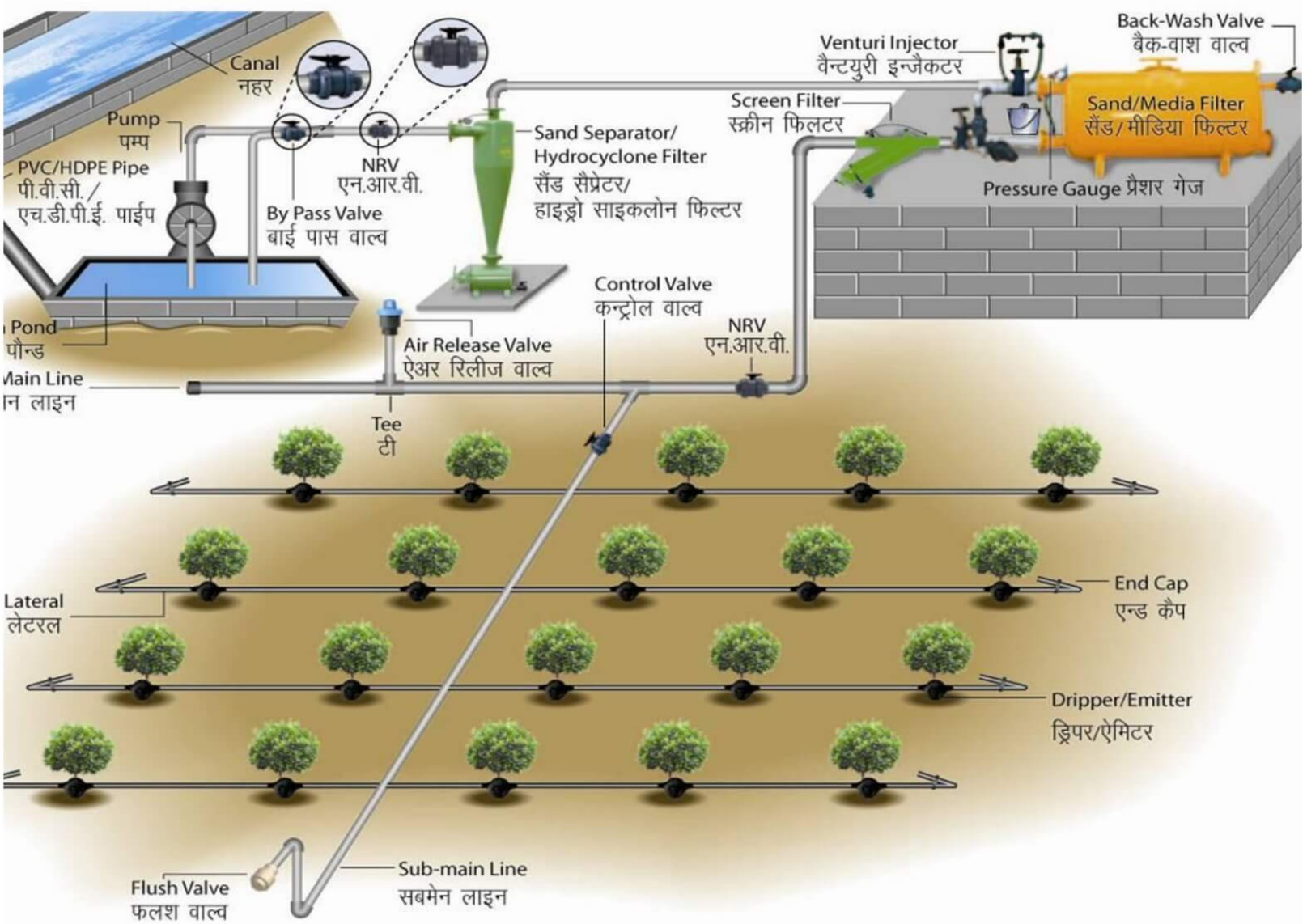

# WATER MANAGEMENT

## INCLUDING MICRO IRRIGATION



# Water Management including Micro Irrigation

This eCourse Developed By  
**TNAU (ICAR)**



# INDEX

SN	LECTURE	PAGE NO
1	DEVELOPMENT OF IRRIGATION IN INDIA - WATER RESOURCES, IRRIGATION POTENTIAL AND IRRIGATION SYSTEMS OF INDIA	1-12
2	ROLE OF WATER IN PLANT GROWTH – HYDROLOGICAL CYCLE - WATER IN SOIL - PLANT - ATMOSPHERE CONTINUUM - ABSORPTION OF WATER AND EVAPOTRANSPIRATION	13-21
3	SOIL WATER MOVEMENT - SATURATED AND UNSATURATED FLOW AND VAPOUR MOVEMENT - SOIL MOISTURE CONSTANTS AND THEIR IMPORTANCE IN IRRIGATION	22-32
4	SOIL MOISTURE MEASUREMENT	33-41
5	MOISTURE EXTRACTION PATTERN OF CROPS- SOIL MOISTURE STRESS - PLANT WATER STRESS -EFFECTS ON CROP GROWTH	42-48
6	CROP WATER REQUIREMENT - POTENTIAL EVAPOTRANSPIRATION (PET) AND CONSUMPTIVE USE- FACTORS AFFECTING CROP WATER REQUIREMENT - CRITICAL STAGES – WATER REQUIREMENT OF DIFFERENT CROPS	49-56
7	WATER REQUIREMENT FOR DIFFERENT CROPS: IRRIGATION SCHEDULES FOR FIELD CROPS	57-60
8	WATER BUDGETING AND ITS IMPORTANCE - IRRIGATION SCHEDULING - APPROACHES	61-76
9	WATER USE EFFICIENCY (WUE) & INDICES	77-83
10	AGRONOMIC PRACTICES FOR USE OF PROBLEM WATER - SALINE, EFFLUENT, SEWAGE WATER	84-87
11	WATER MANAGEMENT FOR PROBLEM SOILS	88-91
12	WATER MANAGEMENT TECHNOLOGY OPTIONS FOR NON-RICE CROPS	92-99

<b>13</b>	<b>COMMAND AREA DEVELOPMENT- CONTINGENT CROP PLAN IN MAJOR IRRIGATION PROJECTS OF TAMIL NADU - DRAINAGE – IMPORTANCE AND METHODS</b>	<b>100-103</b>
<b>14</b>	<b>WATER LOGGING AND FIELD DRAINAGE</b>	<b>104-111</b>
<b>15</b>	<b>DRIP IRRIGATION AND FERTIGATION</b>	<b>112-131</b>
<b>16</b>	<b>SPRINKLER IRRIGATION</b>	<b>132-144</b>
<b>17</b>	<b>PLASTIC MULCHING FOR CROP PRODUCTION</b>	<b>145-160</b>
<b>18</b>	<b>METHODS OF IRRIGATION - SUITABILITY, ADVANTAGES AND LIMITATIONS</b>	<b>161-184</b>

# 1. DEVELOPMENT OF IRRIGATION IN INDIA - WATER RESOURCES, IRRIGATION POTENTIAL AND IRRIGATION SYSTEMS OF INDIA AND TAMIL NADU

## IMPORTANCE OF IRRIGATION MANAGEMENT

### *Irrigation*

Simply, irrigation can be stated as application of water to the soil for crop growth and development. The application of water to plants is made naturally through rainfall and artificially through irrigation.

Irrigation is defined as the artificial application of water to the soil for the purpose of crop growth or crop production in supplement to rainfall and ground water contribution.

### *Management*

Regulating, the activities based on the various resources for its efficient use and better out put. i.e., allocation of all the resources for maximum benefit and to achieve the objectives, without eroding the environment is called management. Otherwise it can be stated as planning, executing, monitoring, evaluating and re-organizing the whole activities to achieve the target.

### *Irrigation Management*

Management of water based on the soil and crop environment to obtain better yield by efficient use of water without any damage to the environment.

Management of water, soil, plants, irrigation structure, irrigation reservoirs, environment, social setup and it's inter liked relationship are studied in the irrigation management.

For this we have to study

- ◆ The soil physical and chemical properties
- ◆ Biology of crop plants
- ◆ Quantity of water available
- ◆ Time of application of water

## Water Management including Micro Irrigation

- ◆ Method of application of water
- ◆ Climatological or meteorological influence on irrigation and
- ◆ Environment and its changes due to irrigation

Management of all the above said factors constitute **Irrigation Agronomy**: Management of irrigation structures, conveyances, reservoirs constitute **Irrigation Engineering**; and social setup, activities, standard of living, irrigation policies, irrigation association and farmer's participation, cost of irrigation etc., constitute **Socio-economic** study.

Except Economics and Engineering all the other components are grouped under Agronomy. Sociology has a major role in irrigation management in a large system. Hence Engineering, Economics, Social science and Agronomy are the major faculties come under Irrigation Management.

Irrigation management is a complex process of art and science involving application of water from source to crop field. The source may be a river or a well or a canal or a tank or a lake or a pond.

Maintaining the irrigation channels without leakage and weed infestation, applying water to field by putting some local check structure like field inlet and boundaries for the area to be irrigated etc., need some skill. These practices are the art involving practices in irrigation management.

Time of irrigation and quantity of water to be applied (when to irrigate? and how much to irrigate?) based on soil types, climatic parameters, crop, varieties, growth stages, season, quality of water, uptake pattern of water by plants, etc., and method of application (How best to irrigate) includes conveyance of water without seepage and percolation losses and water movement in soil, are the process involving scientific irrigation management.

Simply, it is a systematic approach of art and science involved in soil, plant and water by proper management of the resources (soil, plant and water) to achieve the goal of crop production.

### ***Importance of Irrigation management***

## Water Management including Micro Irrigation

Water is essential not only to meet agricultural needs but also for industrial purposes, power generation, live stock maintenance, rural and domestic needs etc. But the resource is limited and cannot be created as we require. Hence irrigation management is very important:

- ◆ To the development of nation through proper management of water resources for the purpose of crop production and other activities such as industrialization, power generation etc., which in turn provides employment opportunities and good living condition of the people.
- ◆ To store and regulate the water resources for further use or non-season use
- ◆ To allocate the water with proper proportion based on area and crop under cultivation. (Balanced equity in distribution)
- ◆ To convey the water without much loss through percolation and seepage (Efficiency in use)
- ◆ To apply sufficient quantity to field crops. (Optimization of use)
- ◆ To utilize the water considering cost-benefit (Economically viable management)
- ◆ To distribute the available water without any social problem (Judicial distribution)
- ◆ To meet the future requirement for other purposes like domestic use of individual and to protect against famine (Resource conservation).
- ◆ To protect the environment from over use or misuse of water (Environment safe use).

### ***Impact of excess and insufficient irrigation water in crops***

Avoid excess or insufficient water to the crops

Excess irrigation leads to wastage of large amount of water, leaching of plant nutrients, destruction of beneficial microbes, increase of expenses on drainage, accumulation of salt leading to salinity and alkalinity, water logging leading to physiological stress and yield loss or crop failure.

Insufficient irrigation leads to reduction in quality of food grains, loss in crop yield or crop failure, poor soil environment etc.

## Water Management including Micro Irrigation

Water becomes a limiting resource due to the multi-various demand from sectors like agriculture, livestock, industries, power generation and increased urban and rural domestic use. The increasing population increases the needs of industrial complexes and urbanization to meet the basic requirement and also to provide employment opportunities. So the demand for water is increasing day by day and hence, it is essential to study water potential and its contribution to agriculture which in turn is going to feed the growing population.

### *Sources of water*

Rainfall is the ultimate source of all kind of water. Based on its sources of availability it can be classified as surface water and subsurface water.

**Surface water** includes precipitation (including rainfall and dew) water available from river, tank, pond; Lake Etc., Besides, snowfall could able to contribute some quantity of water in heavy snowfall area like Jammu, Kashmir and Himalaya region.

**Subsurface water** includes subsurface water contribution, underground water, well water etc.

### *Rain fall*

Seasons of rainfall can be classified as follows

- |                                |   |                    |
|--------------------------------|---|--------------------|
| 1. Winter (Cold dry period)    | - | January – February |
| 2. Summer (Hot weather period) | - | March – May        |
| 3. Kharif (South-West monsoon) | - | June – September   |
| 4. Rabi (North-East monsoon)   | - | October – December |

### *South-west monsoon*

It comprises the month June, July, August and September which contributes about 70% of rainfall to India except for extreme North of Jammu and Kashmir and extremes South of Tamil Nadu. Hence the success of agriculture in India depends on timely onset, adequate amount and even distribution of this South West Monsoon (SWM). This season is also called as Kharif season.

### *North East monsoon*

## Water Management including Micro Irrigation

It comprises the months of October, November and December. North East Monsoon (NEM) contributed rainfall to South Eastern part of peninsular India Tamil Nadu receives its 60% of rainfall from NEM (North East Monsoon). This season is also called as Rabi season.

### ***Winter***

It comprises of the month of January and February. It contributes very little rainfall.

### ***Summer***

Comprises of the months of March, April and May and contributes little summer showers.

### ***Characteristics of good rainfall***

1. Quantity should be sufficient to replace the moisture depleted from the root zone.
2. Frequency should be so as to maintain the crop without any water stress before it starts to wilt.
3. Intensity should be low enough to suit the soil absorption capacity.

Indian rainfall does not have the above good characteristics to maintain the crop through rainfall alone.

### **Characteristic features of Indian rainfall**

- ◆ Annual Average rainfall is 1190 mm
- ◆ There is wide variation in the quantity of rainfall received from place to place. Highly erratic, undependable, variation in seasonal rainfall either in excess or deficit are the nature of Indian rainfall. For example a place in Rajasthan receives practically nil rainfall at the same time Chirapunji about 3000 mm rainfall.
- ◆ Rainfall is not uniformly distributed throughout the year. It is seasonal, major quantity is in the South West Monsoon, (SWM alone contributing 70% of total rainfall) i.e. in the month of June to September followed by North East Monsoon (NEM) from October to December. It summer and winter the amount of rainfall is very little.

## Water Management including Micro Irrigation

- ◆ With in the season also the distribution is not uniform. A sudden heavy downpour followed by dry spell for a long period is common occurrence.
- ◆ Rainfall distribution over a large number of days is more effective than heavy down pour in a short period, but it is in negative trend in India
- ◆ Late starting of seasonal monsoon
- ◆ Early withdrawal of monsoon and
- ◆ Liability to failure are the freakish behaviour of Indian rainfall. Timely and uniform distribution of rainfall is important for better crop planning and to sustain crop production.

### **IRRIGATION – HISTORY AND STATISTICS**

Irrigation has been practiced since time immemorial, nobody knows when it was started but evidences say that it is the foundation for all civilization since great civilization were started in the river basins of Sind and Nile.

This civilization came to an end when the irrigation system failed to maintain crop production.

There are some evidences that during the Vedic period (400 B.C) people used to irrigate their crops with dug well water. Irrigation was gradually developed and extended during the Hindus, Muslims and British periods.

The Grand Anaicat (KALLANAI) constructed across the river Cauvery is an outstanding example for the irrigation work by a Chola king the great Karikala Cholan during second century. The Veeranarayanan Tank and Gangai Konda Cholapuram tank was constructed during 10<sup>th</sup> century in TN. Anantaraja Sagar in AP was constructed during 13th century.

Early Mauryan king Samudragupta and Ashoka took great interest in the construction of wells and tanks. Later Moghul kings or North India and Hindu kings of South India focused their attention, in the establishment of canals, dams, tanks etc. British Government initiated their work during 19th century in remodeling and renovation of the existing irrigation system. The Upper Ganga canal, Krishna and

## Water Management including Micro Irrigation

Godavari delta system, Mettur and Periyar dams are the great irrigation structures built by the British rulers. After independence, Irrigation activities have been accelerated and number of multipurpose river valley projects like Bhakra-nangal in Punjab, Tungabhadra in Andrapradesh, Damodar Valley in Madhya Pradesh were established.

### ***Irrigation Development during five year plans***

In 1950 – 51 the gross irrigated area was 22.5 million ha. After completion of 1 five year plan the gross irrigated area was enlarged to 26.2 million ha. Further it was gradually increased to 29, 35.5, 44.2, 53.5; 75 million has respectively over the II, III, IV, V, VI & VII five years plans. The expected increase through VIII and IX five year plans area 95 and 105 m ha respectively.

### ***Classification of irrigation work or projects***

The irrigation projects can be classified as 1. major 2. medium 3. minor based on financial limits or expenditure involved in the scheme.

1. Major – more than 50 million Rupees : It covers cultural command area of more than 10,000 hectares
2. Medium – 2.5 million to 50 million Rupees : It covers cultural command area of 2000 – 10,000 hectares
3. Minor – less than 2.5 million Rupees : It covers cultural command area of 2,000 hectares.

The minor irrigation work consists of irrigation tanks, canals and diversion work for the welfare of small of farmers.

Indian has many perennial and seasonal rivers which flow from outside and within the country. Among these some important rivers of different states are given below.

### **Important irrigation projects in India**

State	Project Name
A.P.	Godavari delta system, Krishna delta system, Nagarjuna sagar (Krishna)
Bihar	Gandala

## Water Management including Micro Irrigation

Punjab	Western Jamuna, Bhakranangal Sutlej, Beas
Gujarat	Kakrapare – Tapti Narmada
M.P.	Gandhi sagar (Chambal, Ranap setab, sagar
Maharastra	Bhima Jayakwadi (Godavari)
Kerala	Kalada, Mullai Periyar
Karnataka	Ghataprabha, Malaprapha and Turga
Orissa	Hirkand and mahanathi
U.P	Upper ganga canal, Ramaganga
W.B	Damodar Valley
Rajasthan	Rajasthan Canal (Sutlej)
Tamil Nadu	Mettur – Lower Bhavani Project
	Parambikulam Alliyar Project
	Periyar Vaigai, Cauvery delta
	Tamirabarani, Other river basins in TN is given in Map

### India's water budget

Total geographical area	= 328M.ha.
Average annual rainfall	= 1190mm
In million hectare metre	= 1190 x 328 = 392 M ha m
Contribution from snowfall	= 8 M ha m
Total	= 400 m ha m.

The rainfall below 2.5 mm is not considered for water budgeting, since it will immediately evaporate from surface soil without any contribution to surface water or ground water.

When rainfall occurs, a portion of it immediately evaporates from the ground or transpires from vegetation, a portion infiltrates into the soil and the rest flows over surface as run off.

There are on an average 130 rainy days in a year in the country out of which the rain during 75 days considered as effective rain. The remaining 55 days are very light and shallow which evaporates immediately without any contribution to surface or ground water recharge. Considering all these factors it is estimated that out of 400 million

## Water Management including Micro Irrigation

hectare meter of annual rainfall 70 million hectare meter is lost to atmosphere through evaporation and transpiration, about 115 million hectare meter flows as surface run-off and remaining 215 million hectare meter soaks or infiltrates into the soil profile

### Surface run-off

Surface run off consists of direct run off from rainfall, melting of snowfall and flow in streams generated from ground water. Total surface run-off has been estimated by Irrigation Commission of India in 1972 as follows.

a) Total surface run off	180 M ha m
b) Rain fall contribution	115 M ha m
c) Contribution from outside the country through steams and rivers	20 M ha m
d) Contribution from regeneration from ground water in Stream and rivers	45 M ha m
Total	180 M ha m

### Disposal of surface run off

The surface runoff is disposed in three ways

1. Stored in reservoirs
2. Disappears by means of percolation, seepage and evaporation
3. Goes to sea as waste

The waster stored in reservoirs is lost through evaporation and some amount through seepage. The rest in utilized for various purposes mainly for irrigation and drinking water.

Total surface run off	= 180 M ha m
Stored in reservoir and tanks	= 15 M ha m
Flow in the river	= 165 M ha m
Utilization from the river by diversion tank and direct pumping	= 15 M ha m
Water goes to sea as waste	= 150 M ha m
On full development work expected	= 45 M ha m
utilization Water flows to sea	= 105 M ha m

### Land utilization pattern of India

Total geographical area	= 328.00 M ha
Net area reported	= 307.47 M ha
Area under forest	= 65.90 M ha
Area under non agricultural use, barren and uncultivable waste	= 100.45 M ha
Net Area sown	= 141.12 M ha
Net area irrigated	= 31.20 M ha
Gross area sown	= 164.00 M ha
Gross area irrigated	= 80.50 M ha

### Land utilization pattern in Tamil Nadu

Total geographical area	= 13.00 M ha
Area under forest	= 2.00 M ha
Non agricultural area	= 1.40 M ha
Barren and uncultivated	= 0.80 M ha
Pastures	= 0.20 M ha
Tree	= 0.20 M ha
Culturable waste	= 0.50 M ha
Culturable fallow	= 0.90 M ha
Other fallow	= 0.50 M ha
Gross area under cultivation	= 7.30 M ha
Net area sown	= 6.30 M ha
Gross area irrigated	= 3.50 M ha
Net area irrigated	= 2.70 M ha

### Tamil Nadu Ground Water Potential

Average rainfall	= 850 mm
Ground water potential	= 36872 Mm <sup>3</sup>
G. water utilization	= 19,801 Mm <sup>3</sup>

## Water Management including Micro Irrigation

Unutilized = 46.3%

### Percentage of area depends upon ground water in various parts of Tami Nadu

Salem	= 83%
Dharmapuri	= 65.3%
Coimbatore	= 51.3%
Madurai	= 45.1%
Trichy	= 34.9%
Tirunelveli	= 35.0%

### Water Resources in India and Tamil Nadu

#### Distribution of irrigated area in '000 hectares

	Canal	Tanks	Wells	Other
India	12,776	4,123	12,034	2,601
Tamil Nadu	931	924	820	35

#### World Irrigation Statistics

Sl.No.	Countries	Area irrigated in million hectares
1	Australia	1.150
2	Botswana	0.002
3	Brazil	0.141
4	Burma	0.753
5	Canada	0.627
6	Ethiopia	0.030
7	France	2.600
8	India	37.640
9	Indonesia	3.797
10	Iran	4.000
11	Iraq	3.107
12	Israel	0.153
13	Japan	3.390
14	Pakistan	11.970

## Water Management including Micro Irrigation

15	USSR	9.900
16	USA	16.932
17	China	74.000

Agrifair

## **2. ROLE OF WATER IN PLANT GROWTH – HYDROLOGICAL CYCLE - WATER IN SOIL - PLANT - ATMOSPHERE CONTINUUM - ABSORPTION OF WATER AND EVAPOTRANSPIRATION**

### **IMPORTANCE OF WATER – THE LIQUID GOLD**

Plants and any form of living organisms cannot live without water, since water is the most important constituent about 80 to 90% of most plant cell.

**Role of water in crop and crop production can be grouped as**

#### **A) Physiological importance**

- The plant system itself contains about 90% of water
- Amount of water varies in different parts of plant as follows
- Apical portion of root and shoot >90%
- Stem, leaves and fruits -70-90%
- Woods -50-60%
- Matured parts -15-20%
- Freshly harvested grains -15-20%
- It acts as base material for all metabolic activities. All metabolic or biochemical reactions in plant system need water.
- It plays an important role in respiration and transpiration
- It plays an important role in photosynthesis
- It activates germination and plays an important role in plant metabolism for vegetative and reproductive growth
- It serves as a solvent in soil for plant nutrients
- It also acts as a carrier of plant nutrients from soil to plant system
- It maintains plant temperature through transpiration
- It helps to keep the plant erect by maintaining plant's turgidity
- It helps to transport metabolites from source to sink

#### **B) Ecological Importance**

- It helps to maintain soil temperature

## Water Management including Micro Irrigation

- It helps to maintain salt balance
- It reduces salinity and alkalinity
- It influences weed growth
- It influences atmospheric weather
- It helps the beneficial microbes
- It influences the pest and diseases
- It supports human and animal life
- It helps for land preparation like ploughing, puddling, etc.,
- It helps to increase the efficiency of cultural operations like weeding, fertilizer application etc., by providing optimum condition.

The multifarious uses of good quality water for the purpose of irrigation, industrial purposes, power generation, livestock use, domestic use for urban and rural development, are increasing the demand for water. Due to increasing cost of irrigation projects and limited supply of good quality water, it becomes high valuable commodity and hence it is stated as Liquid Gold. Further, historical evidences indicate that all civilization established on water base due to proper management and disappear due to improper management of the same water base. All the superior varieties, organic manure, inorganic fertilizer, efficient labour saving implements, better pest and disease management techniques can be implemented only when sufficient water is applied to the crop. The diversified value of water can be quoted as follows:

Water as a source of sustenance

Water as an instrument of agriculture

Water as a community good

Water as mean of transportation

Water as an industrial commodity

Water as a clean and pure resource

Water as a beauty

## Water Management including Micro Irrigation

Water as a destructive force to be controlled

Water as a fuel for urban development

Water as place for recreation and wild life habitat

As indicated by Sir.C.V.Raman water is the ELIXER of Life which makes wonders in earth if it is used Properly, Efficiently, Economically, Environmentally, Optimally, Equitably and Judicially.

### **Hydrological Cycle**

*Solid – liquid- gaseous form (refer any standard book)*

State of water as solid – ice, its temperature – presence as ice, icebergs and Ice Mountains, ice glaciers and their role on water availability

As water – ocean – extent of ocean – their role on water availability

Gaseous form – clouds and their formation – precipitation – forms of precipitation etc.

### **Water in Soil - plant - atmosphere continuum**

#### **Soil physical properties influencing irrigation**

Soil is a three-phase system comprising of the solid phase made of mineral and organic matter and various chemical compounds, the liquid phase called the *soil moisture* and the gaseous phase called the *soil air*. The main component of the solid phase is the soil particles, the size and shape of which give rise to pore spaces of different geometry. These pore spaces are filled with water and air in varying proportions, depending on the amount of moisture present. The presence of solid particles, liquid (soil solution) and gas (soil air) constitute a complex polyphasic system. The volume composition of the three main constituents in the soil system varies widely. A typical silt loam soil, for example, contains about 50 per cent solids, 30 per cent water and 20 per cent air. In addition to the three basic components, soil usually contains numerous living organisms such as bacteria, fungi, algae, protozoa, insects and small animals which directly or indirectly

affect soil structure and plant growth. The most important soil properties influencing irrigation are its infiltration characteristics and water holding capacity. Other soil properties such as soil texture, soil structure, capillary conductivity, soil profile conditions, and depth of water table are also given consideration in the management of irrigation water.

### **Water Relations of Soil**

The mineral and organic compounds of soil form a solid (though not rigid) *matrix*, the interstices of which consist of irregularly shaped pores with a geometry defined by the boundaries of the matrix (Fig. 7.5). The pore space, in general, is filled partly with soil air and liquid vapour and partly with the liquid phase of soil water. Soil moisture is one of the most important ingredients of the soil. It is also one of its most dynamic properties. Water affects intensely many physical and chemical reactions of the soil as well as plant growth.

The properties of water can be explained by the structure of its molecule. Two atoms of hydrogen and one atom of oxygen combine to form a molecule largely determined by that of the oxygen atom. The two hydrogen atoms take up practically no space. Water molecules do not exist individually. The hydrogen in the water serves as a connecting link from one molecule to the other.

Soil serves as the storage reservoir for water. Only the water stored in the root zone of a crop can be utilized by it for its transpiration and buildup of plant tissues. When ample water is in the root zone, plants can obtain their daily water requirements for proper growth and development. As the plants continue to use water, the available supply diminishes, and unless more water is added, the plants stop growing and finally die. Before the stage is reached when crop growth is adversely affected, it is necessary to

## Water Management including Micro Irrigation

irrigate again. The amount of water to be applied to each irrigation, and the frequency of irrigation are dependent on the properties of the soil and the crop to be irrigated.

**Kinds of soil water:** When is added to a dry soil either by rain or irrigation, it is distributed around the soil particles where it is held by adhesive and cohesive forces; it displaces air in the pore spaces and eventually fills the pores. When all the pores, large and small, are filled, the soil is said to be saturated and is at its maximum retentive capacity. The following re the three main classes of soil water:

(i) Hygroscopic water. Water held tightly to the surface of soil particles by adsorption forces.

(ii) Capillary water. Water held by forces of surface tension and continuous films around soil particles and in the capillary spaces.

(iii) Gravitational water. Water that moves freely in response to gravity and drains out of the soil.

Adhesion is the attraction of solid surfaces for water molecules. Adhesion is operative only at the solid-liquid interface and hence the film of water established by it is very thin. Cohesion is the attraction of water molecules for each other. This force makes possible a marked thickness of the films of water established by h y d r a t i o n u n t i l t h e y a t t a i n microscopic size. As the film gets thicker and thicker the forces of gravity act and water flows downward through the large pores. Such water is loosely held. Thus, when a soil is near saturation it is easy to remove an increment of water, but as moisture becomes less

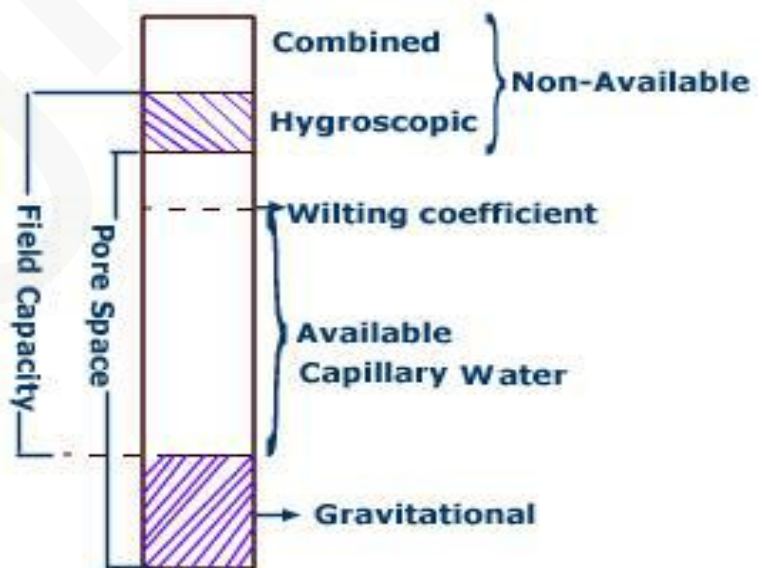

and less in the soil, the greater will be the force required to remove a unit amount of moisture.

When a dry soil sample is exposed to water vapour, it will take up moisture. The amount adsorbed depends on the nature and magnitude of the surface exposed, the temperature and the degree of humidity. The moisture thus adsorbed is the water of hydration, water of adhesion, or commonly the hygroscopic water. When the air saturation is 100 per cent the maximum amount of such moisture will be acquired.

The capillary water is held between tensions of about 31 atmospheres and one-third atmosphere. Between 31 and 15 atmospheres, capillary adjustment is very sluggish. Comparatively easy movement does not occur until the water film thickens and pressures near one-third atmosphere are reached. As a result of its energy relations, the capillary water is the only fluid water bearing solutes, that remains in the soil for any length of time, if drainage is satisfactory. Thus, it functions physically and chemically as the soil solution. The principal factors influencing the amount of capillary water in soils are the structure, texture and organic matter. The finer the texture of the mineral soil particles, the greater is likely its capillary capacity. Granular soil structure produces higher capillary capacity. Presence of organic matter increases the capillary capacity.

Water held in the soil at tensions of one-third atmosphere or less will respond to gravity and move downward, hence the name gravitational water. The water thus affected is that present in the non-capillary (large) pores. Of the three forms of water, only capillary and gravitational water are of interest to the irrigationists since hygroscopic water is not available to plants.

**Movement of water into soils:** The movement of water from the surface into the soil is called *infiltration*. The infiltration characteristics of the soil are one of the dominant variables influencing irrigation. *Infiltration rate* is the soil characteristic determining the maximum rate at which water can enter the soil under specific conditions, including the presence of excess water. It has the dimensions of velocity.

The actual rate at which water is entering the soil at any given time is termed the *Infiltration velocity*.

The infiltration rate decreases during irrigation. The rate of decrease is rapid initially and the infiltration rate tends to approach a constant value. The nearly constant rate that develops after some time has elapsed from the start of irrigation is called the *basic infiltration rate*.

### **Factors Affecting Infiltration Rate**

The major factors affecting the infiltration of water into the soil are the initial moisture content, condition of the soil surface, hydraulic conductivity of the soil profile, texture, porosity, and degree of swelling of soil colloids and organic matter, vegetative cover, duration of irrigation or rainfall and viscosity of water. The antecedent soil moisture content has considerable influence on the initial rate and total amount of infiltration, both decreasing as the soil moisture content rises. The infiltration rate of any soil is limited by any restraint to the flow of water into and through the soil profile. The soil layer with the lowest permeability, either at the surface or below it, usually determines the infiltration rate. Infiltration rates are also affected by the porosity of the soil which is changed by cultivation or compaction. Cultivation influences the infiltration rate by increasing the porosity of the surface soil and breaking up the surface seals. The effect of tillage on infiltration usually lasts only until the soil settles back to its former condition of bulk density because of subsequent irrigations.

Infiltration rates are generally lower in soils of heavy texture than on soils of light texture. The influence of water depth over soil on infiltration rate was investigated by many workers. It has been established that in surface irrigation, increased depth increases initial infiltration slightly but the head has negligible effect after prolonged irrigation. Infiltration rates are also influenced by the vegetal cover. Infiltration rates on grassland is substantially higher than bare uncultivated land. Additions of organic matter increase infiltration rate substantially. The hydraulic conductivity of the soil profile often change during infiltration, not only because of increasing moisture content, but also

because of the puddling of the surface caused by reorientation of surface particles and washing of finger materials into the soil. Viscosity of water influences infiltration. The high rates of infiltration in the tropics under otherwise comparable soil conditions is due to the low viscosity of warm water.

### **Soil Moisture Retention and Movement**

The moisture content of a sample of soil is usually defined as the amount of water lost when dried at  $105^{\circ}\text{C}$ , expressed either as the weight of water per unit weight of dry soil or as the volume of water per unit volume of bulk soil. Although useful, such information is not a clear indication of the availability of water for plant growth. The difference exists because the water retention characteristics may be different for different soils.

The forces that keep soil and water together are based on the attraction between the individual molecules, both between water and soil molecules (adhesion) and among water molecules themselves (cohesion). In the wet range surface tension is the most important force, while in the dry range adsorption is the main factor. Thus, the higher the moisture content, the smaller is the attraction of the soil for water. The energy of water tension in a soil depends on the specific surface as well as the structure of the soil and on its solute content. When water is present in fine capillaries, the energy with which it is attached is a function of the surface tension and capillary size but when it is present in bigger pores, it is bound loosely to the soil and can be acted upon by gravity. When salts dissolve in water, they decrease the free energy of water. Soil water, by virtue of the salts dissolved in it has a lower free energy than pure water. Further, soil water that is bound to solid particles as hygroscopic water is tightly held by the surface of contact and has a low free energy by virtue of binding forces. Thus, there are two types of interactions which decrease the free energy of water, namely, (i) due to the solubility of salts, (ii) due to the interaction of water and solid surface. Both these add together in decreasing the

## Water Management including Micro Irrigation

energy of soil water. Thus, the retention of water in the soil and the tendency of water to move in the soil are consequences of energy effects.

Agrifair

### 3. SOIL WATER MOVEMENT - SATURATED AND UNSATURATED FLOW AND VAPOUR MOVEMENT - SOIL MOISTURE CONSTANTS AND THEIR IMPORTANCE IN IRRIGATION

#### Soil Moisture Tension

Soil moisture tension is a measure of the tenacity with which water is retained in the soil and shows the force per unit area that must be exerted to remove water from a soil. The tenacity is measured in terms of the potential energy of water in the soil measured, usually with respect to free water. It is usually expressed in atmospheres, the average air pressure at sea level. Other pressure units like cm of water or cm or mm of mercury are also often used (1 atmosphere = 1036 cm of water or 76.39 cm of mercury). It is also sometimes expressed in bars ( $1 \text{ bar} = 10^6 \text{ dynes / cm}^2 = 1023 \text{ cm of water column}$ ).

$$1 \text{ millibar} = \frac{1}{1000} \text{ bar}.$$

Soil moisture tension is brought about at the smaller dimensions by surface tension (capillarity), and at the higher dimensions by adhesion. Buckingham (1907) introduced the concept of 'capillary potential' to define the energy with which water is held by soil. This term, however, does not apply over the entire moisture range. In a wet soil, as long as there is a continuous column of water, it might be called 'hydrostatic potential', in the intermediate range the term 'capillary potential' is appropriate. In the dry range the term 'hygroscopic potential' would be suitable. However, the term 'soil moisture potential', 'soil moisture suction' and 'soil moisture tension' are often used synonymously to cover the entire range of moisture (Khonke, 1968).

**pF of soils:** Scholfield (1935) suggested the use of the logarithm of soil moisture tension and gave the symbol pF of this logarithm which is an exponential expression of a free-energy difference (based on the height of a. water column above free-water level in

cm). The pF function, analogous to the acidity-alkalinity scale pH, is defined as the logarithm to the base 10 of the numerical value of the negative pressure of the soil moisture expressed in cm of water.

$$pF = \log_{10} h \quad \text{in which}$$
$$h = \text{soil moisture tension in cm of water}$$

If the osmotic tension is negligible, *i.e.*, at low salt concentration, the pF of the soil moisture may nearly equal the logarithm of the capillary tension expressed in cm of water.

### **Soil Moisture Characteristics**

Soil moisture tension is not necessarily an indication of the moisture content of neither the soil nor the amount of water available for plant use at any particular tension. These are dependent on the texture, structure and other characteristics of the soil and must be determined separately for each soil. Generally sandy soils drain almost completely at low tension, but fine textured clays still hold a considerable amount of moisture even at such high tensions that plant growing in the soil may wilt. Moisture extraction curves, also called moisture characteristic curves, which are plots of moisture content versus moisture tension, show the amount of moisture a given soil holds at various tensions. Knowledge of the amount of water held by the soil at various tensions is required, in order to understand the amount of water that is available to plants, the water that can be taken up by the soil before percolation starts, and the amount of water that must be used for irrigation.

### **Soil moisture stress**

Soil-moisture tension as discussed in the preceding paragraphs is based on pure water. Salts in soil water increase the force that must be exerted to extract water and thus affect the amount of water available to plants. The increase in tension caused by salts is from *osmotic pressure*. If two solutions differing in concentration are separated by a

membrane impermeable to the dissolved substance, such as a cell membrane in a plant root, water moves from the solution of lower concentration to the one of higher concentration. The force with which water moves across such a membrane is called osmotic pressure and is measured in atmospheres.

Plant growth is a function of the soil moisture stress which is the sum of the soil moisture tension and osmotic pressure of soil solution. In many irrigated soils, the soil solution contains an appreciable amount of salts. The osmotic pressure developed by the soil solution retards the uptake of water by plants. Plants growing in a soil in which the soil-moisture tension is, say, 1 atmosphere apparently can extract enough moisture for good growth. But if the osmotic pressure of the soil solution is, say, 10 atmospheres, the total stress is 11 atmospheres and the plants cannot extract enough water for good growth. Thus, for successful crop production in soils having appreciable salts, the osmotic pressure of the soil solution must be maintained as low as possible by controlled leaching and the soil moisture tension in the root zone is maintained in a range that will provide adequate moisture to the crop.

### **Soil moisture constants**

Soil moisture is always being subjected to pressure gradients and vapour pressure differences that cause it to move. Thus, soil moisture cannot be said to be constant at any pressure. However, it has been found experimentally that certain moisture contents described below are of particular significance in agriculture and these are often called soil moisture 'constants'.

***Saturation capacity.*** When all the pores of the soil are filled with water, the soil is said to be under saturation capacity of *maximum water holding capacity*. The tension of water at saturation capacity is almost zero and it is equal to free water surface.

***Field capacity.*** The field capacity of soil is the moisture content after drainage of gravitational water has become very slow and the moisture content has become relatively stable. This situation usually exists one to three days after the soil has been thoroughly

## Water Management including Micro Irrigation

wetted by rain or irrigation. The terms field capacity, field-carrying capacity, normal moisture capacity and capillary capacity are often used synonymously. At field capacity, the large soil pores are filled with air, the micro pores are filled with water and any further drainage is slow. The field capacity is the upper limit of available moisture range in soil moisture and plant relations. The soil moisture tension at field capacity varies from soil to soil, but it generally ranges from 1/10 to 1/3 atmospheres.

Field capacity is determined by ponding water on the soil surface in an area of about 2 to 5 sq m and permitting it to drain for one to three days, with surface evaporation prevented. Evaporation may be prevented by spreading a polythene sheet or a thick straw mulch on the ground surface. One to three days after the soil is thoroughly wetted, soil samples are collected with an auger from different soil depths at uniform intervals throughout the wetted zone. The moisture content is determined by the gravimetric method.

**Moisture equivalent.** Moisture equivalent is defined as the amount of water retained by a sample of initially saturated soil material after being subjected to a centrifugal force of 1000 times that of gravity for a definite period of time, usually half an hour. To determine the moisture equivalent, a small sample of soil is whirled in a centrifuge with a centrifugal force of 1000 times that of gravity. The moisture remaining in the sample is determined. This moisture content when expressed as moisture percentage on oven dry basis, gives the value of the moisture equivalent. In medium textured soils, the values of field capacity and moisture equivalent are nearly equal. In sandy soils, the field capacity exceeds the moisture equivalent. In very clayey soils, the field capacity is generally lower than the moisture equivalent.

**Permanent wilting percentage:** The permanent wilting percentage, also known as permanent wilting point or wilting coefficient, is the soil moisture content at which plants can no longer obtain enough moisture to meet transpiration requirements; and remain wilted unless water is added to the soil. At the permanent wilting point the films

## Water Management including Micro Irrigation

of water around the soil particles are held so tightly that roots in contact with the soil cannot remove the water at a sufficiently rapid rate to prevent wilting of the plant leaves. It is a soil characteristic, as all plants whose root systems thoroughly permeates the soil will wilt at nearly the same soil moisture content when grown in a particular soil in a humid atmosphere.

The moisture tension of a soil at the permanent wilting point ranges from 7 to 32 atmospheres, depending on soil texture, on the kind and condition of the plants, on the amount of soluble salts in the soil solution, and to some extent on the climatic environment. Since this point is reached when a change in tension produces little change in moisture content, there is little difference in moisture percentage regardless of the tension taken as the permanent wilting point. Therefore, 15 atmospheres is the pressure commonly used for this point.

The *wilting range* is the range in soil-moisture content through which plants undergo progressive degrees of permanent or irreversible wilting, from wilting of the oldest leaves to complete wilting of all leaves. At the permanent wilting point, which is the top of this range, plant growth ceases. Small amounts of water can be removed from the soil by plants after growth ceases, but apparently the water is absorbed only slowly and is enough only to maintain life until more water is available. The moisture content at which the wilting is complete and the plants die is called the *ultimate wilting*. Although the difference in the amount of water in the soil between the two points may be small, there may be a big difference in tension. At the ultimate wilting point soil-moisture tension may be as high as 60 atmospheres.

The most common method of determining the permanent wilting percentage is to grow indicator plants in containers, usually in small cans, holding about 600 grams of soil. Sunflower plant is commonly used as the indicator plant. The plants are allowed to wilt and are then placed in a chamber with an approximately saturated atmosphere to test them for permanent wilting. The residual soil moisture content in the container is then

## Water Management including Micro Irrigation

calculated which is the permanent wilting percentage. The determination of moisture content at 15 atmosphere tension which is the usually assumed value of permanent wilting point can be done by the pressure membrane apparatus (Richard, 1947).

**Available water.** Soil moisture between field capacity and permanent wilting point is referred to as readily available moisture. It is the moisture available for plant use. In general, fine-textured soils have a wide range of water between field capacity and permanent wilting point than coarse textured soils. In contrast, sandy soils with their larger proportion of non-capillary pore space release most of their water within a narrow range of potential because of the predominance of large pores. Illustrates the three kinds of soil water and the difference in available water between typical sandy loam and silt loam soils. Table below present the range of available water holding capacities of different soil textural groups. For irrigation system design, the total available water is calculated for a soil depth based on the root system of a mature plant of the crop to be grown.

Range of available water holding capacity of soils

Soil type	Per cent moisture, based on dry weight of soil		Depth of available water per until of soil
	Field capacity	Permanent wilting percentage	cm per meter depth of soil
Find sane	3-5	1-3	2-4
Sandy loam	5-15	3-8	4-11
Silt loam	12-18	6-10	6-13
Clay loam	15-30	7-16	10-18
Clay	25-40	12-20	16-30

### Movement of water within soils

The movement of water within the soil controls not only the rate of infiltration but also the rate of supply of moisture to plant roots and the rate of underground flow to springs and streams and recharge of ground water. Water in the liquid phase flows

through the water filled pore space under the influence of gravity. In the films surrounding soil particles (under unsaturated conditions), it moves under the influence of surface tension forces. Water also diffuses as vapour through the air-filled pore spaces along gradients of decreasing vapour pressure. In all cases, the movement is along gradients of decreasing water potential.

### Terminology

*Water intake.* The movement of irrigation water from the soil surface into and through the soil is called water intake. It is the expression of several factors, including infiltration and percolation.

*Percolation.* Percolation is the downward movement of water through saturated or nearly saturated soil in response to the force of gravity. Percolation occurs when water is under pressure or when the tension is smaller than about  $\frac{1}{2}$  atmosphere. *Percolation rate* is synonymous with infiltration rate with the qualitative provision of saturated or near saturated conditions.

*Interflow.* Interflow is the lateral seepage of water in a relatively pervious soil above a less pervious layer. Such water usually reappears on the surface of the soil at a lower elevation.

*Seepage.* Seepage is the infiltration (vertically) downward and lateral movements of water into soil or substrata from a source of supply such as a reservoir or irrigation canal. Such water may reappear at the surface as wet spots or seeps or may percolate to join the ground water or may join the subsurface flow to springs or streams. Seepage rate depends on the wetted perimeter of the reservoir or the canal and the capacity of the soil to conduct water both vertically and laterally.

*Permeability (1) Qualitative.* It is the characteristic of a pervious medium relating to the readiness with which it transmits fluids.

(2) *Quantitative*. The specific property governing the rate or readiness with which a porous medium transmits fluids under standard conditions. According to this definition, equations used for expressing flow, which take into account the properties of the fluid, should give the same soil permeability value for all fluids which do not alter the medium.

The term *intrinsic permeability* is used as a permeability factor independent of the fluid. It must, however, be remembered that the factors which tend to change the permeability of the soil matrix to water will influence this value and prevent its use unless they can be measured or evaluated separately.

*Hydraulic conductivity*. Hydraulic conductivity is the proportionality factor  $k$  in Darcy's law ( $v=ki$ , in which  $v$  is the effective flow velocity and  $i$  is the hydraulic gradient). It is, therefore, the effective flow velocity at unit hydraulic gradient and has the dimensions of velocity ( $LT^{-1}$ ). The values of  $k$  depend on the properties of the fluid with the porous medium, such as swelling of a soil. A soil that has high porosity and coarse open texture has a high hydraulic conductivity value. For two soils of the same 'total' porosity, the soil with small pores has lower conductivity than the soil with large pores because of the resistance to flow in small pores. A soil with pores of many sizes conducts water faster if the large pores form a continuous path through the profile. In fine-textured soils, hydraulic conductivity depends almost entirely on structural pores. In some soils, particles are cemented together to form nearly impermeable layers commonly called *hardpans*. In other soils, very finely divided or colloidal material expands on absorbing water to form an impervious gelatinous mass that restricts the movement of water.

*Hydraulic head*. Hydraulic head is the elevation with respect to a standard datum at which water stands in a riser pipe or manometer connected to the point in question in the soil. This will include elevation head, pressure head, and also the velocity head, if the terminal opening of the sensing element is pointed upstream. For non-turbulent flow of water in soil the velocity head is negligible. In unsaturated soil a porous cup must be used for establishing hydraulic contact between the soil water and water in a manometer. Hydraulic head has the dimensions of length ( $L$ ).

*Hydraulic gradient* Hydraulic gradient is the rate of change of piezometric or hydraulic head with distance. Hydraulic gradient of ground water records the head consumed by friction in the flow in unit distance since in ground water flow the velocity heads are generally negligible.

*Hydraulic equilibrium of water in soil* It is the condition for zero flow rate of liquid or film water in the soil. This condition is satisfied when the pressure gradient force is just equal and opposite to the gravity force.

### **Movement of water under saturated conditions**

Poiseuille's law forms the basis for a number of different equations which have been developed for determining the hydraulic conductivity of the soil for knowledge of its pore-size distribution. Pore size is of outstanding significance, as its fourth power is proportional to the rate of saturated flow. This indicates that saturated flow under otherwise identical conditions decreases as the pore size decreases. Generally the rate of flow in soils of various textures is in the following sequence.

Sand > loam > clay

### **Moisture movement under unsaturated conditions**

As drainage proceeds in a soil and the larger pores are emptied of water the contribution of the hydraulic head or the gravitational component to total potential becomes progressively less important and the contribution of the matric potential  $\psi_m$  becomes more important. The effect of pressure is generally negligible because of the continuous nature of the air space. The solute potential (osmotic potential)  $\psi_s$  does not affect the potential gradient unless there is unusual concentration of solute at some point in the soil. The negligible effect of solute potential is due to the fact that both solutes and water are moving. Thus, in moisture movement under unsaturated conditions, the potential  $\psi$  (Equation 7.28) is the sum of the matric potential  $\psi_m$  and, to some extent the

gravitational potential  $\psi_g$ . In horizontal movement, only  $\psi_m$  applies. Under conditions of downward movement, capillary and gravitational potentials act together. In upward capillary movement  $\psi_m$  and  $\psi_g$  oppose one another. For unsaturated flow (Equation 7.28) may be rewritten as:

$$v = -k \frac{\Delta(\psi_m + \psi_g)}{\Delta l}$$

The direction of  $l$  is the path of greatest change in  $(\psi_m + \psi_g)$ .

Under unsaturated conditions Darcy's law (Equation 7.28) is still applied but with some modifications and qualifications. It is applicable to unsaturated flow if  $k$  is regarded as a function of water content, i.e.  $k(\theta)$  in which  $\theta$  is the soil moisture content. As the soil moisture content and soil moisture potential decreases, the hydraulic conductivity decreases very rapidly, so that  $\psi_{\text{soil}}$  is  $-15$  bars,  $k$  is only  $10^{-3}$  of the value at saturation. According to Philip (1957 a), the rapid decrease in conductivity occurs because the larger pores are emptied first, which greatly decreases the cross-section available for liquid flow. When the continuity of the films is broken, liquid flow no longer occurs.

In unsaturated soil moisture movement, also called capillary movement,  $k$  (Equation 7.28) is often termed as *capillary conductivity*, though the term hydraulic conductivity is also frequently used. The unsaturated conductivity is a function of soil moisture content as well as number, size and continuity of soil pores. At moisture contents below field capacity, the capillary conductivity is so low that capillary movement is of little or no significance in relation to plant growth. Many investigations have shown that capillary rise from a free water table can be an important source of moisture for plants only when free water is within 60 or 90 cm of the root zone.

Movement of unsaturated flow ceases in sand at a lower tension than in finer textured soils, as the water films lose continuity sooner between the larger particles. The wetter the soil, the greater is the conductivity for water. In the 'moist range', the range of unsaturated flow in soils of various textures is in the following order:

### **Sand < loam < clay**

It may be noticed that this is the reverse of the order encountered in saturated flow. However, in the 'wet range' the unsaturated conductivity occurs in the same or similar order as saturated conductivity.

### **Water vapour movement**

Movement of soil water in unsaturated soils involves both liquid and vapour phases. Although vapour transfer is insignificant in high soil water contents, it increases as void space increases. At a soil moisture potential of about-15 pascals, the continuity of the liquid films is broken and water moves only in the form of vapour. Diffusion of water vapour is caused by a vapour pressure gradient as the driving force. The vapour pressure of soil moisture increases with the increase in soil moisture content and temperature, it decreases with the increase in soluble salt content.

Water vapour movement is significant only in the 'moist range'. In the 'wet range' vapour movement is negligible because there are few continuous open pores. In the 'dry range' water movement exists, but there is so little water in the soil that the rate of movement is very small.

Water vapour movement goes on within the soil and also between soil and atmosphere, for example, evaporation, condensation and adsorption. The rate of diffusion of water vapour through the soil is proportional to the square of the effective porosity, regardless of pore sizes. The finer the soil pores, the higher is the moisture tension under which maximum water vapour movement occurs. In a coarse textured soil pores become free of liquid water at relatively low tensions and when the soil dries out there is little moisture left for vapour transfer. But a fine textured soil retains substantial amounts of moisture even at high tensions, thus permitting vapour transfer. It is interesting to note that maximum water vapour movement in soils vapour movement is of greatest importance for the growth and survival of plants.

## 04.SOIL MOISTURE MEASUREMENT

Soil moisture is estimated both by direct and indirect method. Direct methods involves the determination of moisture in the soil while indirect methods estimate amount of water through the properties of water I the soil. In direst methods moisture is estimated thermo- gravimetrically either through oven – drying or by volumetric method.

### Oven drying method

Soil sample is collected in a moisture can and wet weight of the sample is recorded. The soil sample is dried in hot air oven at 105 °C until constant weight is obtained and dry weight of the sample is recorded.

$$\text{Moisture content (on weight basis)} = \frac{\text{Wet weight}-\text{Dry weight} \times 100}{\text{Dry weight}}$$

### Volumetric method

Soil sample is taken with a core sample or with a tube auger whose volume is known. The amount of water present in the soil sample is estimated by drying in the oven. The volumetric moisture content can also be estimated from the moisture content estimated on dry weight basis.

The most common instrument used for estimating soil moisture by indirect methods is; tensiometer, gypsum block, neutron probe, pressure plate and pressure membrane apparatus.

### Tensiometer

Tensiometer is a sealed, airtight, water-filled tube (barrel) with a porous tip on one end and a vacuum gauge on the other, as shown in Figure 1. A tensiometer measures soil water suction (negative pressure), which is usually expressed as tension. This suction is equivalent to the force or energy that a plant must exert to extract water from the soil. The instru- ment must be installed

properly so that the porous tip is in good contact with the soil, ensuring that the soil-water suction is in equilibrium with the water suction in the tip. The suction force in the porous tip is transmitted through the water column inside the tube and displayed as a tension reading on the vacuum gauge. Soil-water tension is commonly expressed in units of bars or centibars. One bar is equal to 100 centibars (cb).

The suction at the tip is transmitted to the vacuum gauge because of the

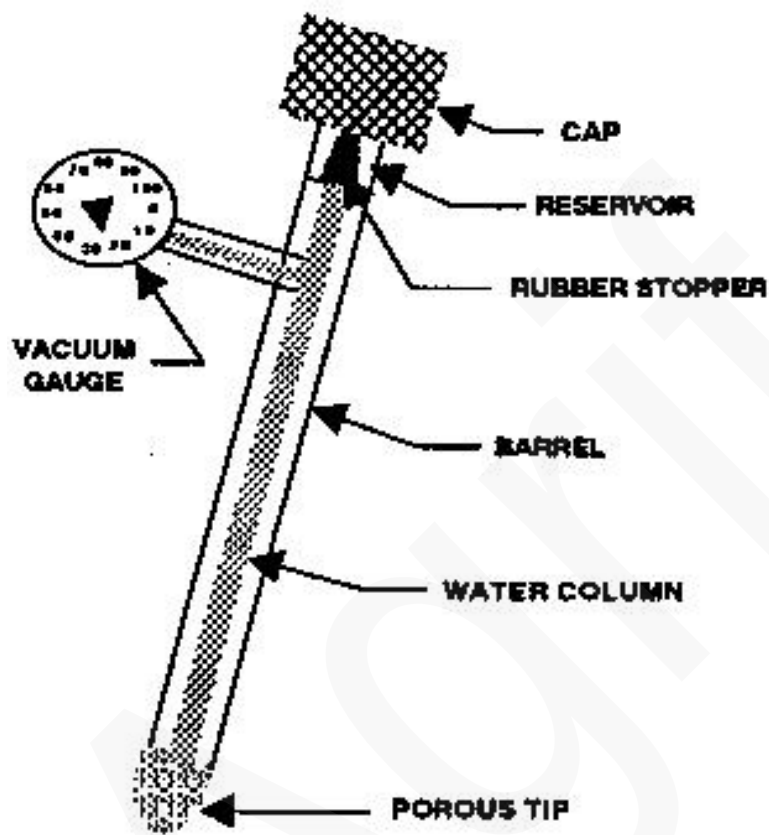

cohesive forces between adjacent water molecules. As the suction approaches approximately 0.8 bar (80 cb), the cohesive forces are exceeded by the suction and the water molecules separate. When this occurs, air can enter the tube through the porous tip and the tensiometer no longer functions correctly. This condition is referred to as *breaking tension*. Tensiometers work in the range from 0 to 0.8 bar. The suction scale on the vacuum gauge of most commercial tensiometers reads from 0

to 100 cb.

Tensiometers are quite affordable for scheduling irrigation. The cost ranges from \$25 to \$50 each, depending on length of the barrel, which ranges from 6 to 72 inches. The only other equipment required is a small hand-held vacuum pump used for calibration and periodic servicing. Tensiometers are easy to use but may give faulty readings if they are not serviced regularly.

Tensiometers are best suited for use in soils that release most of their plant-available water (PAW) at soil-water suctions



between 0 and 80 cb. Soil textures in this category are those that consist of sand, loamy sand, sandy loam, and the coarser-textured range of loam and sandy clay loam. Many clayey and silty soils still retain over 50 percent of their plant-available water at suctions greater than 80 cb, which is outside the working range of a tensiometer. Tensiometers are not recommended for clayey and silty soils unless irrigation is to be scheduled before 50 percent depletion of the plant-available water, which is the normal practice for some vegetable crops such as tomatoes.

### Gypsum block or Electrical resistance blocks

Electrical resistance blocks consist of two electrodes enclosed in a block of porous material, as shown in Figure 2. The block is often made of gypsum, although fiberglass or nylon is sometimes used. Electrical resistance blocks are often referred to as *gypsum blocks* and sometimes just *moisture blocks*. The electrodes are connected to insulated lead wires that extend upward to the soil surface.

Resistance blocks work on the principle that water conducts electricity. When properly installed, the water suction of the porous block is in equilibrium with the soil-water suction of the surrounding soil. As the soil moisture changes, the water content of the porous block also changes. The electrical resistance between the two electrodes increases as the water content of the porous block decreases. The block's resistance can be related to the water content of the soil by a calibration curve.

To make a soil-water reading, the lead wires are connected to a resistance meter containing a voltage source. The meter normally reads from 0 to 100 or 0 to 200. High readings on the scale (corresponding to low

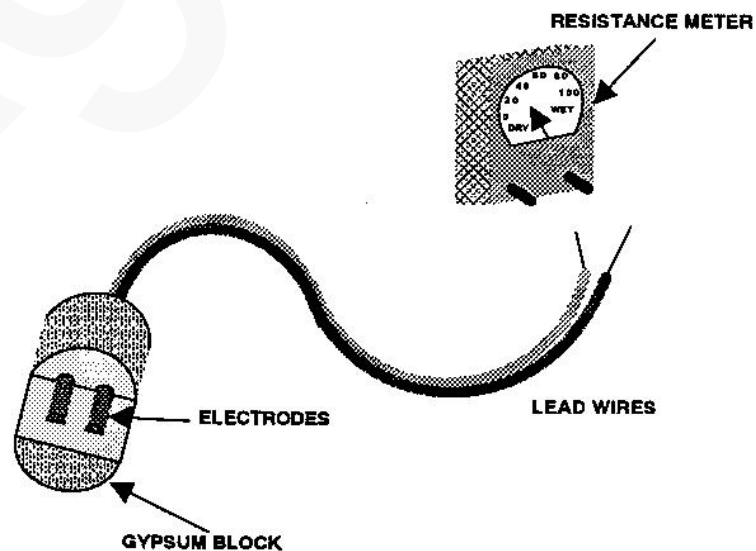

electrical resistance) indicate high levels of soil-water, whereas low meter readings indicate low levels.

Because of the pore size of the material used in most electrical resistance blocks, particularly those made of gypsum, the water content and thus the electrical resistance of the block does not change dramatically at suctions less than 0.5 bar (50 cb). Therefore, resistance blocks are best suited for use in fine-textured soils such as silts and clays that retain at least 50 percent of their plant-available water at suctions greater than 0.5 bar. Electrical resistance blocks are not reliable for determining when to irrigate sandy soils where over 50 percent of the plant-available water is usually depleted at suctions less than 0.5 bar.

### Neutron moisture meter

Soil moisture can be estimated quickly and continuously with neutron moisture meter without disturbing the soil. Another advantage is that soil moisture can be estimated from large volume of soil. This meter scans the soil about 15 cm diameters around the neutron probe in wet soil and 50 cm in dry soil. It consists of a probe and a scalar or rate meter. This contains a fast neutron source which may be a mixture of radium and beryllium or americium and

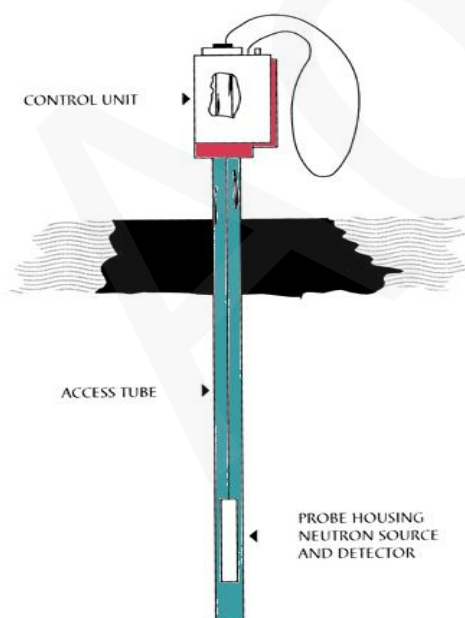

beryllium. Access tubes are aluminum tubes of 50-100 cm length and are placed in the field when the moisture has to be estimated. Neutron probe is lowered in to access tube to a desired depth. Fast neutrons are released from the probe which scatters in to soil. When the neutrons encounter nuclei of hydrogen atoms of water, their speed is reduced. The scalar or the rate meter counts of slow neutrons which are directly proportional to water molecule. Moisture content of the soil can be known from the calibration curve with count of slow neutrons.

### **Pressure membrane and pressure plate Apparatus**

Pressure membrane and pressure plate apparatus is generally used to estimate field capacity, permanent wilting point and moisture content at different pressure. The apparatus consists of an air tight metallic chamber in which porous ceramic pressure plate is placed. The pressure plate and soil samples are saturated and are placed in the metallic chamber. The required pressure of 0.33 or 15 bar is applied through a compressor. The water from the outlet till equilibrium against applied pressure is achieved. After that, the soil samples are taken out and oven-dried for determining the moisture content.

### **Phene Cell**

The Phene cell works on the principle that a soil conducts heat in relation to its water content. By measuring the heat conducted from a heat source and calibrating the conductance versus water content for a specific soil, the Phene cell can be used reliably to determine soil-water content. Because the Phene cell is placed at the desired soil depth, a separate cell is needed for each depth at each location to be monitored. For irrigating small acreages, the total cost of using the Phene cell is less than that of the neutron probe. For large acreages, the neutron probe may be more cost effective.

### **Time Domain Reflectometer**

The time domain reflectometer (TDR) is a new device developed to measure soil-water content. Two parallel rods or stiff wires are inserted into the soil to the depth at which the average water content is desired. The rods are connected to an instrument that sends an electromagnetic pulse (or wave) of energy along the rods. The rate at which the wave of energy is conducted into the soil and reflected back to the soil surface is directly related to the average water content of the soil. One instrument can be used for hundreds of pairs of

rods. This device, just becoming commercially available, is easy to use and reliable.

### **Selecting the Right Device**

When cost, ease of use, and reliability are considered, tensiometers and electrical resistance blocks are usually the most practical devices for measuring soil-water in North Carolina. For best results, tensiometers and electrical resistance blocks must be properly installed, maintained, and calibrated for the primary soil types in each field. Installation Procedures for tensiometers and resistance blocks are described in the next section. The gravimetric method can be used to calibrate tensiometers and electrical resistance blocks on the farm.

### **Preparing and Installing Measuring Devices**

#### ***Tensiometers***

Before a tensiometer is installed, the porous tip should be soaked in water overnight. The tube should then be filled with boiled (air-free) water, and the gauge and tip should be tested using a small, hand-held vacuum pump (available from tensiometer manufacturers). The vacuum pump should also be equipped with a vacuum gauge. It is used to create a vacuum in the tensiometer.

After the porous tip of the tensiometer is saturated, attach the vacuum pump to the top of the tensiometer with the cap removed. Use the pump to evacuate air from the tensiometer barrel. The vacuum gauge reading on the pump and on the tensiometer should be the same. Furthermore, this reading should remain constant for several seconds, indicating that air is not leaking through the porous tip.

If tension cannot be maintained, the tip or barrel has probably been damaged or cracked. The most common cause of failure is a crack in the porous tip resulting from rough handling. A cracked tip allows air to enter the barrel so that tension forces in the soil are not correctly transmitted to the gauge. Tips, seals and gauges can be replaced by the tensiometer manufacturer.

After the vacuum pump test has been completed, the rubber seal in the cap should be tested. Fully assemble the tensiometer and place it on a table or surface so that the porous tip is exposed to the air. Water will begin evaporating from the tip. Within a few minutes, the tension reading on the gauge should begin to increase. If it does not, the rubber stopper in the cap is not providing a good seal and should be replaced. Otherwise, the tensiometer is ready for installation. It should be transported to the field

with the tip submerged in a container of water or wrapped in a moist cloth so that tension is not broken before installation.

A probe slightly smaller than the diameter of the porous tip (for example, a steel rod, broom handle, or tube) is used to make a hole in the soil for the tensiometer. The depth of the hole should be about 1/4 to 1 inch less than the actual depth for the porous tip (Figure 3). Pour 1/4

cup of water into the hole to moisten the soil at the bottom. Insert the tensiometer and gently push it down to the desired depth, usually one-half the effective root zone depth. To ensure good contact between the soil and the porous tip, push the tip into the

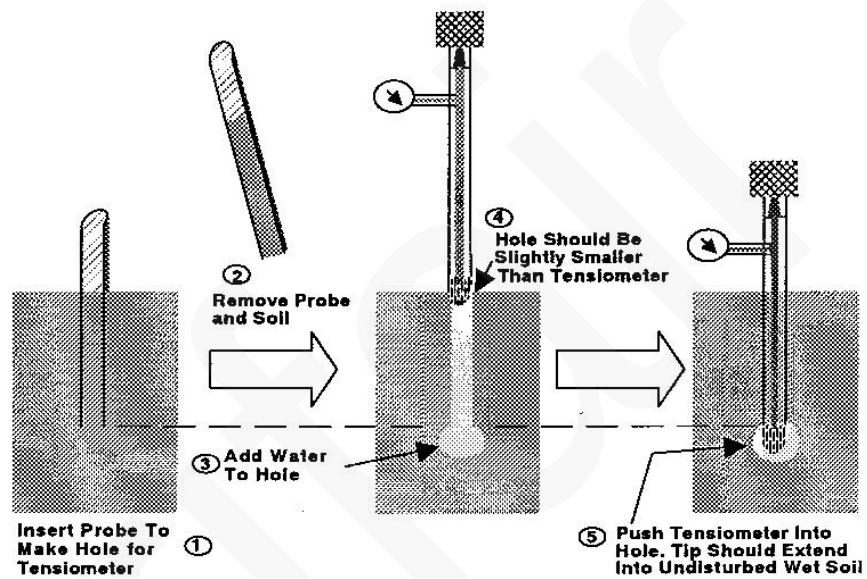

undisturbed soil just below the depth created by the probe. After the probe has been installed, the soil and porous tip usually reach equilibrium within 24 hours, and the instrument is then ready to use.

The tensiometer should be installed to one-half the effective root depth. The porous tip must be in good contact with the adjacent soil.

Field experiences with tensiometers have been mixed. When properly installed and maintained, tensiometers are reliable. Unsatisfactory results are usually caused by inadequate maintenance. Sandy soils, which are best suited for tensiometers, have low levels of plant-available water. In coarse, sandy soils the water content may decrease from field capacity to less than 20 percent of the plant-available water within three days. At this depletion rate, tension can exceed 80 cb within three days, breaking the water column (tension). The soil may then appear dry and the crop may show visible signs of stress. Because tension was broken and the tensiometer is no longer functioning correctly, however, the gauge shows a low tension (high soil moisture). Thus the irrigator concludes that the tensiometer is unreliable. Tensiometers should be read every day

(sometimes twice a day in very sandy soils) until you obtain a feel for how fast the soil dries after rainfall or irrigation.

Whenever tension is broken, the tensiometer must be serviced. This includes refilling the instrument with boiled water and checking it with the vacuum pump. Adding a little food coloring to the boiled water makes it easier to see whether water is still present in the tensiometer. Air bubbles in the water column tend to collect at the top of the barrel and appear clear compared to the colored water. The water column should always be free of air bubbles, and water should always be stored in the reservoir. It may be necessary to add water to the reservoir during the season even if tension is not broken.

### ***Electrical Resistance Blocks***

Like tensiometers, electrical resistance blocks should be soaked overnight before they are installed in the field. A soil probe should be used to make a hole to the desired installation depth. The hole should be slightly larger than the moisture block so the block slips in easily. After placing the resistance block in the hole, backfill the hole with a thick soil slurry using soil from the installation depth. Since fine-textured soils do not dry as rapidly as sandy soils, resistance blocks do not need to be read as frequently as tensiometers. Normally, three to four readings per week are adequate.

The electrical resistance of soil-water is affected by substances dissolved in the water. The exchange of water between the soil and the block over the course of the irrigation season may gradually alter the electrical resistance of the block and eventually alter the calibration. This is not a serious problem in North Carolina soils unless highly saline water is used for irrigation. Since electrical resistance blocks are inexpensive, however, new calibrated blocks should be installed at the beginning of each growing season.

### **Positioning Soil-Water Measuring Devices**

If tensiometers or electrical resistance blocks are used, at least one device should be located in each of the major soil types in the irrigated field. For most soils irrigated in North Carolina, the effective root depth is about 12 inches. The soil-water measuring device should therefore be installed to a depth of 6 inches. In soils with a dramatic textural change within 12 inches of the soil surface, such as a loamy sand surface texture overlying a sandy clay loam, one device should be installed in the center of the effective root zone portion of each layer.

## Water Management including Micro Irrigation

Soil-water measuring devices should be installed in the plant row. Install them as soon as possible after planting so that roots will grow around them and water extraction will resemble natural field conditions. Flag each device so that it can be easily found in the growing crop. Mark the end of each row containing a device.

Agrifair

## **LEC. 05. MOISTURE EXTRACTION PATTERN OF CROPS- SOIL MOISTURE STRESS - PLANT WATER STRESS -EFFECTS ON CROP GROWTH**

### **Water as a Plant Component**

The factors influencing the water relations of plants, and thus their growth and yield responses, may be grouped into the following

- I. Soil factors – soil moisture content, texture, structure, density, salinity, fertility, aeration, temperature and drainage.
- II. Plant factors – type of crop, density and depth of rooting, rate of root growth, aerodynamic roughness of the crop, drought tolerance and varietal effects.
- III. Weather factors – sunshine, temperature, humidity, wind and rainfall.
- IV. Miscellaneous factors – soil volume and plant spacing, soil fertility, and crop and soil management

The metabolic activity of cells and plants is closely related to their water content. Growth of plants is controlled by the rates of cell division and enlargement and by the supply of organic and inorganic compounds required for the synthesis of new protoplasm and cell walls. A decreasing water content is accompanied by a loss of cell turgor\* and wilting, cessation of cell enlargement, closure of stomata reduction of photosynthesis and interference with many basic metabolic processes. Eventually, continued dehydration causes disorganization of the protoplasm and death of most organisms. The relation of water content to physiological processes is shown strikingly in seeds, where respiration and other physiological activities increase manifold as the water content increases. In photosynthesis, water is as important a reagent as carbondioixde. An essential function of water in plants is as the solvent in which gases, minerals, and other solutes enter plant cells and move from cell to cell and tissue to tissue within the plant. The permeability of most cell walls and membranes to water results in a continuous liquid phase extending throughout the plant in which translocation of solutes occurs. Water is a reactant or reagent in many physiological processes including photosynthesis and hydrolytic processes such as the hydrolysis of starch to sugar. Water is essential to maintain

## Water Management including Micro Irrigation

sufficient turgidity for growth of cells and maintenance of the form and position of leaves and new shoots.

The total quantity of water required for the essential physiological functions of the plant is usually less than five per cent of all the water absorbed. Most of the water entering the plant is lost in transpiration, directly contributing little to its growth. However, failure to replace the water lost by transpiration results in the loss of turgidity, cessation of growth, and eventual death of the plant from dehydration.

The following are the main areas of water-plant relationship: (1) water absorption, (2) water conduction and translocation, and (3) water loss or transpiration.

In determining the importance of water in crop productivity we have to understand clearly all the three processes – absorption, translocation and transpiration. We will have to analyse the effect of these processes on plant growth and crop yield in order to recognize the steps which are needed to regulate and modify the cropping systems with a view to obtain the maximum water use efficiency.

*Amount of water in plants:* The amounts of water varies in different plant parts. The apical portions of the root and stem contain 90 per cent or more water. Leaves and young fruits are other organs which are rich in water. When the organs mature, their water content decreases. The woods of large trees may contain about 50-60 per cent moisture whereas the stems of wheat, barley and sorghum contain about 60-70 per cent water which at harvest time may decline to 5-10 per cent. Freshly harvested grains of most crops contain 10-15 per cent of water. Indeed, it is the moisture content of these grains which determines their storage life, viability and germinability.

*Absorption of water in soil-plant-atmosphere system.* The root system is extremely variable in different crop plants. The variability exists in rooting depth, root

## Water Management including Micro Irrigation

length and horizontal distribution of roots. These are further influenced by environmental factors and the genetic constitution. Nevertheless, both the properties of soil and the roots determine the water uptake by roots. The roots of cereals, apparently, occupy more surface area of the soil than other crops. For example, it has been shown that cereal roots extend to 200-4000 cm/cm<sup>2</sup> of soil surface area as against 15-200 cm/cm<sup>2</sup> for non-graminaceous plants.

It is desirable to consider water absorption in the total soil-plant-atmosphere system instead of the roots alone. In this system, one can partition the system in such a manner so that the involvement of different plant parts is taken into account. The flow rate of water in this system is given by the following equation:

$$\text{Flow rate} = \frac{\Psi_{\text{soil}} - \Psi_{\text{root surface}}}{r_{\text{soil}}} = \frac{\Psi_{\text{root surface}} - \Psi_{\text{xylem}}}{r_{\text{root}}} = \frac{\Psi_{\text{xylem}} - \Psi_{\text{leaf}}}{r_{\text{xylem}}} = \frac{\Psi_{\text{leaf}} - \Psi_{\text{air}}}{r_{\text{leaf}} + r_{\text{leaf}}}$$

in which,  $\Psi$  is the water potential at various sites of the system and  $r$  is the corresponding resistance.

Water absorption by roots is dependent on the supply of water at the root surface. The two main phenomena concerned with this are the movement of water to the root surface and the growth of roots into the soil mass. As the soil dries out from a saturated state, the rate of water movement in the soil decreases rapidly. The water movement in the soil drier than field capacity controls the distance in the soil from which roots can extract water. Thus, under the conditions where the water extracted by roots is not

## Water Management including Micro Irrigation

frequently replaced by rain or irrigation, it is important that the root system must expand continuously or else have already occupied a large enough volume of soil to provide the plant with sufficient water to replace the transpiration losses. Hence, all the factors which affect root growth or the occupation by roots of a large enough soil volume, will also affect the absorption of water by plants.

The actual entry of water into the roots is affected by the extent of the absorbing zone of the roots, the permeability of the root cortex to water movement and the water potential at the root surface. The movement of water through the root and conducting elements of the leaves xylem to the leaves is initiated and largely controlled by the transpiration from the leaves in response to the water potential gradient extending from the soil water, through the plant to the atmosphere. The water moves from the xylem strands of the leaf across the mesophyll tissue and through the cell walls bordering the sub-stomatal cavities where the liquid vapourizes and diffuses out of the leaves through the stomatal openings. Transpiration, though an energy-controlled process, is modified by the soil, plant and atmospheric factors which govern the potential gradients in the various parts of the water path to the leaf surface.

### **Moisture stress and plant response**

As mentioned previously, plant-water relations consist of a group of interrelated and interdependent processes. Thus, the internal water balance or degree of turgidity of a plant depends on the relative rates of water absorption and water loss, and is affected by the complex of atmospheric, soil and plant factors that modify the rates of absorption and transpiration.

Water moves in response to a potential gradient. When the plant roots are in equilibrium with the soil water potential, and the soil water potential gradients are near zero, a base level of leaf turgor or plant water potential is reached. Under the conditions of low evaporation demand during the night and early morning (prior to sunrise) the values of water potential are often at or near this level. An increase in the rate of

transpiration, coincident with the increase in evaporation, during the day, causes a decrease in the turgor pressure of the upper leaves and the development of water potential gradients through the plant from the evaporating surface of the leaves to the absorbing surface of the roots. Conditions are often such that the rate of water loss exceeds the rate of water absorption, causing an internal water deficit to develop in the plant. It is this internal water deficit, through its influence on many of the physiological processes in the plant that is directly responsible for the growth and yield of a crop under the prevailing conditions.

The yield of a crop is the integrated result of a number of physiological processes. Water stress can affect photosynthesis and respiration. It can also affect growth and reproduction. Reduction in leaf area, cell size and inter-cellular volume are common under water stress. Dehydration of protoplasm may be responsible for decreasing several physiological processes. Water stress produces important changes in carbohydrate and nitrogen metabolism of plants. Water stress at certain critical stages of plant growth causes more injury than at other stages. For example, irrigation at the crown root initiation stage has been shown to be essential for increased yield of wheat crop.

### **Moisture extraction pattern**

The moisture extraction pattern reveals about how the moisture is extracted and how much quantity is extracted at different depth level in the root zone. The moisture extraction pattern shows the relative amount of moisture extracted from different depths within the crop root zone.

The moisture extraction pattern of plant growing in a uniform soil without a restrictive layer and with adequate supply of available soil moisture throughout the zone is shown in figure.

## Water Management including Micro Irrigation

It is seen from the figure that about 40% of the total moisture is extracted from the first quarter of the root zone, 30% from second quarter, 20% from the third quarter and 10% from last further quarter.

This indicates that in most of the crops the effective root zone will be available in the 1<sup>st</sup> quarter and it does not mean that the last quarter will not need any water. Hence soil moisture measurements at different depths in the root zone has to be taken.

- a) To estimate the soil moisture status and
- b) To work out the irrigation quantity to be applied

### Rooting characteristics and moisture extraction pattern

The root system is extremely variable in different crop plants.

The variability exists in rooting depth, root length and horizontal distribution of roots. These are further influenced by environmental factors and the genetic constitution.

The roots of cereals apparently occupy more surface area of the soil than other crops. For example, it has been proved that cereals' roots extend to 200-400 cm m<sup>2</sup> of soil surface area as against 15-200 cm m<sup>2</sup> for most graminaceous plants.

The amount of soil moisture that is available to the plant is determined by the moisture characteristics of the soil depth and the density of the roots. The moisture characteristics of soil like FC and PWP cannot be altered so easily and greater possibilities lie in changing the rooting characteristics of plants system to go deeper and denser and more proliferation to tap water from deeper layers of soil as well as from the larger surface area.

## Water Management including Micro Irrigation

Plants vary genetically in their rooting characteristics (Figure) Vegetable crops like onion, potato, carrot etc., have very sparse rooting system and unable to use all the soil water in the root.

Rice, Grasses, sorghum, maize, sugarcane have very fibrous dense root system which can extract much water from soil. Millets, groundnut, grams are moderately deep rooted.

Maize, sorghum, lucerne, cotton and perennial plants have deep root system and can utilize effectively the moisture stored in root zone as well as in the unexploited deeper zones. Crops which have dense and deep root system like cotton, sorghum, red gram tolerate high reduction of soil water content. Shallow rooted crops like rice, potato, tomato tolerate low level of soil water reduction. Moderately deep rooted crops like millets, groundnut, grams tolerate medium level of soil water reduction.

The root growth of the crop plants is affected by

1. Genetic nature
2. High water table
3. Shallow nature of soil and permeability of soil layer
4. Soil fertility
5. Salt status of soil

Effective root zone depth

It is depth in which active root proliferation occurs and where maximum water absorption is taking place. It is not necessary that entire root depth should be effective.

## 6. CROP WATER REQUIREMENT - POTENTIAL EVAPOTRANSPIRATION (PET) AND CONSUMPTIVE USE- FACTORS AFFECTING CROP WATER REQUIREMENT - CRITICAL STAGES – WATER REQUIREMENT OF DIFFERENT CROPS

### Crop water Requirement

Crop water requirement is the water required by the plants for its survival, growth, development and to produce economic parts. This requirement is applied either naturally by precipitation or artificially by irrigation. Hence the crop water requirement includes all losses like:

- a) Transpiration loss through leaves (T)
- b) Evaporation loss through soil surface in cropped area (E)
- c) Amount of water used by plants (WP) for its metabolic activities which is estimated as less than 1% of the total water absorption. These three components cannot be separated so easily. Hence the ET loss is taken as crop water use or crop water consumptive use.
- d) Other application losses are conveyance loss, percolation loss, runoff loss, etc., (WL).
- e) The water required for special purposes (WSP) like puddling operation, ploughing operation, land preparation, leaching, requirement, for the purpose of weeding, for dissolving fertilizer and chemical, etc.

Hence the water requirement is symbolically represented as:

$$WR=T+E+WP+WL+WSP$$

(The other application losses and special purposes are mostly indented for wet land cultivation. Hence for irrigated dry land crop the ET loss alone is accounted for crop water requirement).

The estimations of the water requirement of crop are one of the basic needs for crop planning on the farm and for the planning of any irrigation project.

## Water Management including Micro Irrigation

Water requirement may be defined as the quantity of water required by a crop or diversified pattern of crop in a given period of time for its normal growth under field conditions at a place.

Water requirement includes the losses due to ET or CU and losses during the application of irrigation water and the quantity of water required for special purposes or operations such as land preparation, transplanting, leaching etc., Hence it may be formulated as follows

$$WR = ET \text{ or } Cu + \text{application loss} + \text{water for special needs.}$$

It can also be stated based on “Demand” and “supply source” as follows

$$WR = IR + ER + S$$

Where,

- IR - Irrigation requirement
- ER - Effective rainfall
- S - Contribution from ground water table.

Hence the idea about crop water requirement is essential for farm planning with respect to total quantity of water needed and its efficient use for various cropping schemes of the farm or project area. This crop water requirement is also needed to decide the stream size and design the canal capacity.

The combined loss of evaporation and transpiration from a cropped field is termed as evapotranspiration which is otherwise known as consumptive use and denoted as ET and this is a part of water requirement.

$$CU = E + T + WP$$

Therefore,

$$WR = CU + WL + WSP$$

## Water Management including Micro Irrigation

The crop water requirement can also be defined as water required meeting the evapotranspiration demand of the crop and special needs in case of wet land crop and which also includes other application losses both in the case of wet land and garden land crops. This is also known as crop water demand.

The crop water requirement varies from place to place, from crop to crop and depends on agro-ecological variation and crop characters. The following features which mainly influence the crop water requirement are:

### 1) Crop factors

- a) Variety
- b) Growth stages
- c) Duration
- d) Plant population
- e) Crop growing season

### 2) Soil factors

- a) Structure
- b) Texture
- c) Depth
- d) Topography
- e) Soil chemical composition

### 3) Climatic factors

- a) Temperature
- b) Sunshine hours
- c) Relative humidity
- d) Wind velocity
- e) Rainfall

### 4) Agronomic management factors

## Water Management including Micro Irrigation

- a) Irrigation methods used
  - b) Frequency of irrigation and its efficiency
  - c) Tillage and other cultural operations like weeding, mulching etc / intercropping
- etc

Based on all these factors, average crop water requirement for various crops have been worked out and given below for tropical conditions.

### **Irrigation requirement**

The field irrigation requirement of crops refers to water requirement of crops exclusive of effective rainfall and contribution from soil profile and it may be given as follows

- IR -  $WR - (ER + S)$
- IR - Irrigation requirement
- WR - Water requirement
- ER - Effective rainfall
- S - Soil moisture contribution

Irrigation requirement depends upon the

- a) Irrigation need of individual crop based on area of crop
- b) Losses in the farm water distribution system etc.

All the quantities are usually expressed in terms of water depth per unit of land area (ha/cm) or unit of depth (cm).

### **Net irrigation requirement**

It is the actual quantity of water required in terms of depth to bring the soil to field capacity level to meet the ET demand of the crop.

It is the water applied by irrigation alone in terms of depth to bring the field to field capacity level. To work out the net irrigation requirement, ground water contribution and other gains in soil moisture are to be excluded. It is the amount of irrigation water required to bring the soil moisture level in the effective root zone to field capacity, which in turn meet the ET effective root zone to field capacity, which in turn meet the ET demand of the crop. It is the difference between the F.C and the soil moisture content in the root zone before starting irrigation.

$$d = \sum_{i=1}^n \frac{M_{fci} - M_{bi}}{100} \times A_i \times D_i$$

d = Net irrigation water to be applied (cm)

M<sub>fci</sub> = FC in i<sup>th</sup> layer (%)

M<sub>bi</sub> = Moisture content before irrigation in i<sup>th</sup> layer (%)

A<sub>i</sub> = Bulk density (g/cc)

D<sub>i</sub> = depth (cm)

n = number of soil layer

### Gross irrigation requirement

The total quantity of water used for irrigation is termed gross irrigation requirement. It includes net irrigation requirement and losses in water application and other losses. The gross irrigation requirement can be determined for a field, for a farm, for an outlet command area, and for an irrigation project, depending on the need by considering the approximate losses at various stages of crop.

$$\text{Gross irrigation} = \frac{\text{Net irrigation requirement}}{\text{Field efficiency of system}} \times 100$$

### **Irrigation frequency**

Irrigation frequency is the interval between two consecutive irrigations during crop periods. Irrigation frequency is the number of days between irrigation during crop periods without rainfall. It depends upon the rate of uptake of water by plants and soil moisture supply capacity to plant and soil moisture available in the root zone. Hence it is a function of crop, soil and climate. Normally, irrigation should be given at about 50 per cent and not over 60 per cent depletion of the available moisture from the effective root zone in which most of the roots are concentrated.

In designing irrigation system the irrigation frequency to be used, is the time (days) between two irrigation in the period of highest consumptive use of crop growth, i.e. peak consumptive use of crop.

### **Design frequency (days)**

$$= \frac{F C - \text{moisture content of the root zone prior to starting irrigation}}{\text{Peak period consumptive use rate of crop}}$$

### **Irrigation period**

Irrigation period is the number of days that can be allowed for applying one irrigation to a given design area during peak consumptive use period of the crop

### **Irrigation period**

$$= \frac{\text{Net amount of moisture in soil at start of irrigation (FC-PWP)}}{\text{Peak period consumptive use rate of crop}}$$

### Peak period consumptive use of the crop

#### Critical stages for irrigation:

The stage at which the water stress causes severe yield reduction is also known as **critical stage of water requirement**. It is also known as **moisture sensitive period**. Moisture stress due to restricted supply of water during the moisture sensitive period or critical stage will irrevocably reduce the yield. Provision of adequate water and fertilizer at other growth stage will not even help in recovering the yield loss due to stress at critical periods.

In general the mid season stage is most sensitive to water shortage because the shortage during this period will be reflected significantly on yield. For most of the crops the least sensitive stages are ripening and harvesting except for vegetables like Lettuce, Cabbage etc., which need water upto harvesting.

Under scarce condition, in an irrigation project or in a farm, if mono cropping is followed with staggered sowing or planting, it is better to schedule irrigation to crop which has reached mid season stage since it is the most critical stage.

The sensitive stages vary from crop to crop as given below.

#### Sensitive stage of different crops cereals and millets

Crop	-	Critical stages / Sensitive stages
Rice	-	Panicle initiation critical stages. heading and flowering
Sorghum	-	Flowering and grain formation
Maize	-	Just prior to tasseling and grain filling
Cumbu	-	Heading and flowering
Ragi	-	Primordial initiation and flowering
Wheat	-	Crown root initiation, tillering and booting
<b>Oil seeds</b>		
Groundnut	-	Flowering peg initiation and penetration and pod development
Sesame	-	Blooming to maturity
Sunflower	-	Two weeks before and after flowering
Soybean	-	Blooming and seed formation

## Water Management including Micro Irrigation

Safflower	-	From rosette to flowering
Castor	-	Full growing period
<b>Cash crop</b>		
Cotton	-	Flowering and Boll formation
Sugarcane	-	Maximum vegetative stage
Tobacco	-	Immediately after transplanting
<b>Vegetables</b>		
Onion	-	Bulb formation to maturity
Tomato	-	Flowering and fruit setting
Chillies	-	Flowering
Cabbage	-	Head formation to maturity
<b>Legumes</b>		
Alfalfa	-	Immediately after cutting for hay crop and flowering for seed crop
Beans	-	Flowering and pod setting
Peas	-	Flowering and pod formation
<b>Others</b>		
Coconut	-	Nursery stage root enlargement
Potato	-	Tuber initiation and maturity
Banana	-	Throughout the growth
Citrus	-	Flowering, fruit setting and enlargement
Mango	-	Flowering
Coffee	-	Flowering and fruit development

At critical stages, favourable water level should be ensured through timely irrigations

## **7. Water requirement for different crops: *Irrigation schedules for field crops***

### **Rice**

Total water requirement is 1100-1250

The daily consumptive use of rice varies from 6-10 mm and total water is ranges from 1100 to 1250 mm depending upon the agro climatic situation. Of the total water required for the crop, 3% or 40 mm is used for the nursery, 16% or 200 mm for the land preparation i.e. puddling and 81% or 1000 mm for field irrigation of the crop.

The growth of rice plant in relation to water management can be divided into four periods viz.,. Seedling, vegetative, reproductive and ripening. Less water is consumed during seedling stage. At the time of transplanting, shallow depth of 2 cm is adequate and maintained upto 7 days and there after 5 cm of submergence is necessary to facilitate development of new roots. The same water level is required for tiller production during the vegetative phase. At the beginning of the maximum tillering stage the entire water in the field can be drained and left as such for one or two days which is termed as mid season drainage. This mid season drainage may improve the respiratory functions of the roots, stimulate vigorous growth of roots and checks the development of non-effective tillers. Any stress during the vegetative phase may affect the root growth and reduce the leaf area.

During flowering phase 5 cm submergence should be maintained because it is a critical stage of water requirement. Stress during this phase will impair all yield components and cause severe reduction in yield. Excess water than 5 cm is also not necessary especially at booting stage which may lead to delay in heading.

Water requirement during ripening phase is less and water is not necessary after yellow ripening. Water can be gradually drained from the field 15-21 days ahead of harvest of crop. Whenever 5 cm submergence is recommended the irrigation management may be done by irrigating to 5 cm submergence at saturation or one or two

## Water Management including Micro Irrigation

days after the disappearance of ponded water. This will result in 30% saving of irrigation water compared to the continuous submergence.

### **Groundnut**

Total water requirement 500-550 mm

Evapotranspiration is low during the first 35 days after sowing and last 35 days before harvest and reaches a peak requirement between peg penetration and pod development stages. After the sowing irrigation the second irrigation can be scheduled 25 days after sowing i.e. 4 or 6 days after first hand hoeing and thereafter irrigation interval of 15 days is maintained upto peak flowering. During the critical stages the interval may be 7 or 10 days depending upon the soil and climate. During maturity period the interval is 15 days.

### **Finger millet**

Total water requirement: 350 mm

Finger millet is a drought tolerant crop. Pre-planting irrigation at 7 or 8 cm is given. Third day after transplantation life irrigation with small quantity of water is sufficient for uniform establishment. Water is then withheld for 10-15 days after the establishment of seedling for healthy and vigorous growth. Subsequently three irrigations are essential at primordial initiation, flowering and grain filling stages.

### **Sugarcane**

Total water requirement: 1800-2200 mm

Formative phase (120 days from planting) is the critical period for water demand. To ensure uniform emergence and optimum number of tillers per unit area lesser quantity of water at more frequencies is preferable. The response for applied water is more during this critical phase during which the crop needs higher quantity of water comparing, the other two phases. Water requirement, number of irrigations etc., are higher during this period. As there is no secondary thickening of stem, elongation of stem as sink for storage of sugar it is desirable to maintain optimum level of moisture during grand

## Water Management including Micro Irrigation

growth period. Response for water is less in this stage and this will be still less in the ripening stage. During the ripening phase as harvest time approaches soil moisture content should be allowed to decrease gradually so that growth of cane is checked and sucrose content is increased.

### **Maize**

Total water requirement: 500 – 600 mm

The water requirement of maize is higher but it is very efficient in water use. Growth stages of maize crop are sowing, four leaf stage, knee high, grand growth, tasseling, silking early dough and late dough stages. Crop uniformly requires water in all these stages. Of this, tasseling, silking and early dough stages are critical periods.

### **Cotton**

Total water requirement: 550 – 600 mm

Cotton is sensitive to soil moisture conditions. Little water is used by plant with early part of the season and more water is lost through evaporation than transpiration. As the plant grows, the use of water increases from 3 mm / day reaching a peak of 10 mm a day when the plant is loaded with flowers and boll. Water used during the emergence and early plant growth is only 10% of the total requirement. Ample moisture during flowering and boll development stages is essential. In the early stage as well as at the end the crop requires less water. water requirement remains high till the boll development stage. If excess water is given in the stages other than critical stages it encourages the vegetative growth because it is a indeterminate plant thereby boll setting may be decreased. Irrigation is continued until the first boll of the last flush opens, and then irrigation is stopped.

### **Sorghum**

Total water requirement: 350-500 mm

## Water Management including Micro Irrigation

The critical periods of water requirement are booting, flowering and dough stages. The crop will be irrigated immediately after sowing. Next irrigation is given 15 days sowing to encourage development of a strong secondary root system. irrigation prior to heading and ten days after heading are essential for successful crop production.

### Pulses

Total water requirement – 200-450 mm

Mostly the pulse are grown under rainfed condition. Some pulse crops like Redgram, Blackgram, Greengram are grown in summer season as irrigated crop which need 3 to 4 irrigation at critical stages like germination, flowering and pod formation.

### Water requirement of crops

S.No.	Crops	Duration in days	Water requirement (mm)	No. of irrigations
1.	Rice	135	1250	18
2.	Groundnut	105	550	10
3.	Sorghum	100	350	6
4.	Maize	110	500	8
5.	Sugarcane	365	2000	24
6.	Ragi	100	350	6
7.	Cotton	165	550	11
8.	Pulses	65	350	4

## **8. WATER BUDGETING AND ITS IMPORTANCE - IRRIGATION SCHEDULING - APPROACHES**

### **Water budgeting:**

Allocation of the water receipt including anticipated within the crop period and its detailed account of expenditure for efficient and profitable farm management is called as water budgeting.

Water budgeting may be for an irrigation system planned by irrigation engineers; may be for a canal or for an area (block) or may be for a farm according to the need and plan by responsible persons who plan the irrigation efficiency.

### **Importance of water budgeting:**

- Efficient utilization of available recourse (water) for bringing more area under irrigation.
- To increase the productivity of a region / farm.
- To increase cropping intensity of a region / farm
- To tide over some dry-spells
- To reduce excess irrigation and losses caused thereby
- To avoid run off losses

### **Irrigation scheduling**

Irrigation scheduling is defined as frequency with which water is to be applied based on needs of the crop and nature of the soil.

Irrigation scheduling is nothing but number of irrigations and their frequency required to meet the crop water requirement.

Irrigation scheduling may be defined as scientific management techniques of allocating irrigation water based on the individual crop water requirement (ET<sub>c</sub>) under different soil and climatic condition, with an aim to achieve maximum crop production per unit of water applied over a unit area in unit time.

Based on the above definition, the concept made is.

## Water Management including Micro Irrigation

“If we provide irrigation facility the agricultural production and productivity will go up automatically”

Irrigation scheduling is a decision making process repeated many times in each year involving when to irrigate and how much of water to apply? Both criteria influence the quantity and quality of the crop. It indicates how much of irrigation water to be used and how often it has to be given.

### **Effect of application of right amount and excess amount of water**

Excess irrigation is harmful because

- a) It wastes water below root zone
- b) It results in loss of fertilizer nutrients
- c) It causes water stagnation and salinity
- d) It causes poor aeration
- e) Ultimately it damages the crops

However, Irrigation scheduling has its own meaning and importance according to the nature of the work.

### **For irrigation Engineers**

Irrigation scheduling is important to cover more area with available quantity of water or to satisfy the whole command from head to tail reach in the canal or river system.

### **For soil scientists**

It is important that the field should not be over irrigated or under irrigated as both will spoil the chemical and physical equilibrium of the soil.

### **For Agronomists**

It is very much important to get higher yield per unit quantity of water in normal situations and to protect the crop to get as much as possible yield under drought situation by means on supplying water in optimum ratio and minimizing all field losses.

### **Importance of irrigation scheduling**

## Water Management including Micro Irrigation

How much and how often water has to be given depends on the irrigation requirement of the crop.

Irrigation requirement (IR) = Crop water requirement (CWR) – Effective rainfall (ERF)

It can be expressed either in mm/day/ or mm/month

If the crop water requirement of a particular crop is 6 mm per day, it means every day we have to give 6 mm of water to the crop. Practically it is not possible since it is time consuming and laborious. Hence, it is necessary to schedule the water supply by means of some time intervals and quantity. For example the water requirement of 6 mm/day can be scheduled as 24 mm/for every 4 days or 30 mm/for every 5 days or 36 mm/for every 6 days depending upon the soil type and climatic conditions prevailing in that particular place. While doing so we must be very cautious that the interval should not allow the crop to suffer for want of water.

### **Practical considerations in irrigation scheduling**

Before scheduling irrigation in a farm or field or a command, the following criteria should be taken care for efficient scheduling

#### **1. Crop factors**

- a) Sensitiveness to water shortage
- b) Critical stages of the crop
- c) Rooting depth
- d) Economic value of the crop

#### **2. Water delivery system**

- a) Canal irrigation or tank irrigation (It is a public distribution system where scheduling is arranged based on the decision made by public based on the resource availability).
- b) Well irrigation (individual decision is final)

#### **3. Types of soil**

- a) Sandy – needs short frequency of irrigation and less quantity of water
- b) Clay – needs long frequency of irrigation and more quantity of water

#### **4. Salinity hazard**

To maintain favorable salt balance, excess water application may be required rather than ET requirement of the crop to leach the excess salt through deep percolation

#### **5. Irrigation methods**

- a) Basin method allows more infiltration through more wetting surface which in turn needs more water and long interval in irrigation frequency
- b) Furrow method allows less infiltration due to less wetting surface which needs less water and short interval in irrigation frequency.
- c) Sprinkler method needs less water and more frequency
- d) Drip method needs less water and more frequency

#### **6. Irrigation interval**

The extension of irrigation interval does not always save water. The interval has to be optimized based on the agroclimatic situation.

#### **7. Minimum spreadable depth**

We cannot reduce the depth based on the water requirement of the crop alone. The depth should be fixed based on the soil type, rooting nature of the crop and irrigation method followed. The minimum depth should be so as to achieve uniformity of application and to get uniform distribution over the entire field.

### **Theoretical approaches of irrigation scheduling**

#### **I Direct approach**

- a) Depth interval and yield approach
- b) Soil moisture deficit and optimum moisture regime approach
- c) Sensitive crop approach
- d) Plant observation method

#### **II Indirect or predictive approach**

- a) Critical stage or Phenological stage approach

- b) Meteorological or climatological approach

### **III Mathematical approach**

- a) Estimation method approach
- b) Simple calculation method

### **IV system as a whole approach**

- a) Rotational water supply schedule

### **I. Direct approach**

#### **A) Depth interval and yield approach**

In this method, different depths of irrigation water at different time intervals fixed arbitrarily are tried without considering the soil and weather characters.

The irrigation treatment which gives the maximum yield with minimum depth and extended interval is chosen as the best irrigation schedule. Earlier workers have adopted this practice to work out the duty of water for different crops in many irrigation projects. It is the rough irrigation schedule. Hence many irrigation projects which have adopted this practice have failed to achieve the full efficiency?

#### **Disadvantages**

- ❖ Rainfall is not taken into account
- ❖ Ground water contribution is not taken into account
- ❖ Soil parameters are not taken for calculating irrigation requirement and hence this approach is not in use.

#### **B) Soil moisture deficit and optimum moisture regime approach**

This approach considers soil moisture content in the root zone of the crop for fixing the schedule. When the soil moisture reaches a pre fixed value, may be 40% of Available Soil Moisture (ASM) or 50% ASM or 60% ASM, irrigation is given. The degree of depletion is measured through percentage of availability by using gravimetric, tensiometer, resistance block, neutron probe, etc.,

### Disadvantages

- Soil moisture alone is taken into account
- Hence it cannot be taken for all type of soil in particular region
- It varies from soil to soil

### C) Sensitive crop approach

The crops which are grown for their fresh leaves or fruits are more sensitive to water shortage than the crops which are grown for their dry seeds or fruits. Based on their sensitivity the crops can be indexed as below.

#### Sensitivity

Low	Low to Medium	Medium to high	High
Cassava	Alfalfa	Beans	Banana
Millets	Cotton	Citrus	Cabbage
Redgram	Maize	Soybean	Fresh Green
	Groundnut	Wheat	Vegetables
			Rice
			Sugarcane
			Tomato

### D) Plant observation method

Normally in field condition farmers use to adopt this practice for scheduling irrigation. The day to day changes in plant physical character like colour of the plant, erect nature of plant leaves, wilting symptoms, etc., are closely and carefully observed on the whole and not for individual plant and then time of irrigation is fixed according to the crop symptoms. It needs more skill and experience about the crop as well as local circumstances like field condition, the rainy days of that tract etc.,

### Disadvantage

- No accuracy in finding the crop water need

- Sometimes sensitive symptoms are evident only after reaching almost the wilting point. So yield loss will occur.

### **i) Indicator plant technique**

As we have seen already some crops like sunflower, tomato are highly sensitive to water stress which will show stress symptom earlier than other stress tolerating crops. Hence, to know the stress symptoms earlier such sensitive crops are planted in random in the field and based on the stress symptoms noticed in such plants, scheduling of irrigation can be made. This technique is called indicator plant technique.

### **ii) Micro plot technique or indicator plot technique**

In this method a one cubic foot micro plot is made of with coarse textured soil to have more infiltration less water holding capacity and more evaporation than the actual main field. Normally the field soil is mixed with sand in 1:2 ratio and filled in the micro plots made in the field. The seed of the same crop and variety is grown in micro plot with all similar cultural practices as that of the main crop. The crops in micro plot show early stress symptoms than that of main field. Based on this scheduling of irrigation can be made.

## **II Predictive approach of indirect approach**

### **A) Critical stage or phonological stage approach**

The growth period of an annual crop can be divided into four growth stages

Initial stage : from sowing to 10% ground cover

Crop development stage : 10 to 70% ground cover

Mid season stage : flowering to grain setting stage

Late season stage : ripening and harvesting stage

### **B) Meteorological approach**

The basic principles employed with this approach are estimation of daily potential evapo-transpiration rates. Hence it requires knowledge on

## Water Management including Micro Irrigation

- Short term evapo-transpiration rates at various stages of plant development
- Soil water retention characteristics
- Permissible soil water deficit in respect to evaporative demand
- Effective rooting depth of the crop grown

The irrigation scheduling is based on the cumulative pan evaporation and irrigation depth.

Irrigation at ratio of irrigation water (IW) and cumulative pan evaporation (CPE).

$$\text{IW /CPE} = \frac{\text{depth of water to be irrigated}}{\text{Cumulative pan evaporation for particular period}}$$

For example, for ten days cumulative pan evaporation at the rate of 10 mm per day equal to 100 mm (CPE). Irrigation depth to be given is 50 mm. Therefore IW/CPE

ratio is

$$\text{IW/CPE} = \frac{50 \text{ mm (depth)}}{100 \text{ mm (CPE)}} = 0.5$$

Like this many ratio have to be tried and find the best yield performing rabi which can be adopted for scheduling irrigation.

The irrigation depth (IW) for different crops are fixed based on the soil and climatic condition. The ratio of IW / CPE which gives relatively best yield is fixed for each crop by experiment with different rations.

The irrigation depth (IW) divided by the ratio (R) will give the cumulative pan evaporation value at which irrigation is to be made.

For example the irrigation depth (IW) needed is 50 mm and the ratio (R) to be tried is 0.5.

Therefore the cumulative pan evaporation value needed to irrigated the field is  
 $\text{IW} / \text{R} = 50 / 0.5 = 100 \text{ mm}$

## Water Management including Micro Irrigation

If the 100 mm of CPE is attained in 10 days (pan evaporation @ 10 mm per day), once in 10 days irrigation is to be given.

### Advantages

Gives best correlation compared to other formulae where climatic parameters and soil parameters (depth) are considered.

### Disadvantages

This approach is subject to marked influence by the selecting pan site.

### For example

USWB class A open pan evaporimeter reading from June to December amounted to 130 cm when pan is sited on grass field, 150 cm when pan is sited on dry land with fetch of grass, 176 cm when pan is sited on dry land without fetch of grass

Pan readings generally over estimated ET during early stage and maturity stage

## III Mathematical approach

### A) Estimation method approach

It is nothing but scientific prediction mainly based on the climate and soil type. Calculated crop water need and estimated root depth are taken into account in this.

#### a. Soil type

Soil type are classified as follows

- |                 |   |   |
|-----------------|---|---|
| Sandy / shallow | - | Low depth of water and more frequency   |
| Loamy soil      | - | Moderate depth water and less frequency |
| Clay soil       | - | More depth of water and less frequency  |

#### b. Climate

Climates are classified based on **reference ET** as follows:

## Water Management including Micro Irrigation

### Reference ET

4 – 5 mm/day – Low

6 – 7 mm/day – Medium

8 – 9 mm/day – High

### Reference ET (mm/day) for different climatic zones

Climatic zone	Mean daily temp		
	15 <sup>0</sup> C Low	15 – 25 <sup>0</sup> C Medium	> 25 <sup>0</sup> C High
Desert/arid	4-6	7-8	9-10
Semiarid	4-5	6-7	8-9
Sub humid	3-4	5-6	7-8
Humid	1-2	3-4	5-6

The above table is based on the crop water needs during peak period. It is also assumed that there is no rainfall or little occurs during the growing season. Based on this method estimated irrigation schedule is given below for major field crops.

### Estimated irrigation schedule for major field crops in peak periods

Climate	Intervals in days											
	S andy				L oamy				C lay			
	1	2	3*	Depth	1	2	3*	Depth	1	2	3*	Depth
Banana	5	3	2	25	7	5	4	40	10	7	5	55
Cotton	9	6	5	40	11	8	6	55	14	10	7	70
Sorghum	8	6	4	40	11	8	6	55	14	10	7	70
G.nut	6	4	3	25	7	5	4	35	11	8	6	50
Maize	8	6	4	40	11	8	6	55	14	10	7	70
Peas	6	4	3	30	8	6	4	40	10	7	5	50
Soybean	8	6	4	40	11	8	6	55	14	10	7	70
Sugarcane	8	6	4	40	10	7	5	55	13	9	7	70
Sunflower	8	6	4	40	11	8	6	55	14	10	7	70
Wheat	8	6	4	40	11	8	6	55	14	10	7	70
Tomato	6	4	3	30	8	6	4	40	10	7	5	50

1\* - Low temperature of  $15^{\circ}\text{C}$

15- $25^{\circ}\text{C}$

3\*- high temperature of  $>25^{\circ}\text{C}$

2\* - medium temperature of

### **Adjustment in this method for Non peak periods**

#### **a) In early growth stages**

The irrigation could be adjusted with little water and same frequency. But same water and less frequency are not advisable.

#### **b) In late growth stage**

Less frequency with same amount of water is advisable in this period.

#### **c) In rainy days**

The table schedule is to be adjusted when there is contribution from rainfall during crop growth period. This can be adjusted by giving longer interval (high frequency) with little water.

#### **d) For irrigation practice and soil characteristics**

For example, if a maize crop is grown on a clayey soil in a moderately warm climate, according to the table the intervals is 10 days and the depth is 70 mm per application. But based on the irrigation method practiced and soil type, the soil is unable to hold 70mm of water per application. The soil could hold only 50 mm/application. In this situation instead of giving 70 mm for every 10 days, it is possible to give 63 mm for every 9 days or 56 mm for every 8 days or 49 mm for every 7 days or 42 mm for every 6 days. The 49 mm for every 7 days is the approximate interval for local situation. Hence this method of intervals for irrigation can be adopted.

### **B) Simple Calculation Method**

It is based on the estimated depth of irrigation application and calculated irrigation need of the crop over growing season. Hence the influence of climate especially temperature and rainfall is taken for consideration. Hence, it is more accurate than that of the estimated method.

**It involves four steps**

## Water Management including Micro Irrigation

- Estimate the net and gross irrigation depth (d) in mm.
- Calculate the irrigation water need (mm) over total growing season
- Calculate the number of irrigation over total growing season
- Calculate the irrigation interval

### Estimation net and gross irrigation

The net irrigation depth is calculated based on the irrigation depth. This may vary with local irrigation method and practice and soil type. If local data are not available the table given below can be used which will be approximate for most of the field crops. The root depth can be measured locally and adjusted.

### Approximate net irrigation depth (mm)

Soil type	Rooting depth		
	Shallow	Medium	Deep
Sandy	15	30	40
Loamy	20	40	60
Clay	30	50	70

### Root depth of different field crops are Given below

Shallow 30 – 60 cm

Rice, rabi, onion, potato, pineapple, cabbage.

### Medium 50 – 100 cm

Banana, bean, coconut, groundnut, peas, soybean, sunflower, tobacco, tomato, cumbu, pulses

### Deep 90-150 cm

Citrus, grapes, wheat, cotton, maize, wheat, sorghum, soybean

We know very well that all the water applied in the field cannot be used by the plants. There is some water loss through deep percolation, run off etc., To include this unavoidable water loss the field application efficiency (eaf) can be used. The gross irrigation depth includes the water loss through deep percolation and run off.

100 x net irrigation depth

Gross irrigation (d) = -----

## Water Management including Micro Irrigation

Field application efficiency

$$\frac{100 \times n.d \text{ (cm)}}{\text{eaf (\%)}}$$

If reliable data for field application efficiency are not available the efficiency rate given below can be used which are more approximate.

For surface method	= 60%
Sprinkler method	= 75%
Drip method	= 90%

According to the table, the depth is 40 mm for tomato grown on a loamy soil. If furrow irrigation is used, field application efficiency is 60% and therefore gross irrigation depth is

$$\text{Gross irrigation depth } d = \frac{100 \times 40}{60} = 67 \text{ mm}$$

b) Calculation of irrigation water need for total growing season

Tomato crop is planted in February 7<sup>th</sup> and harvested in June 30<sup>th</sup> **Water needs mm/month**

February	March	April	May	June	Total
67	110	166	195	180	718

The water need is calculated based of ET value of the crop during that period

c) Calculate the number of irrigation over total growing period

$$\text{Number of irrigation} = \frac{\text{Total water need}}{\text{Depth}} = \frac{718}{40} = 18$$

## Water Management including Micro Irrigation

40

Duration (days)

d). Irrigation interval = -----

Number of irrigation

143

= ----- = 7.94 =

---

8.0 18

### Conclusion

Irrigation schedule for tomato

Net d = 40 mm

Gross d = 65 mm

Interval = 8 days

Water requirement for peak season

April	May	June	Total
166	195	180	541

Depth (d) = 40 mm

WR = 541

Number of irrigation = -----

d = 40

= 13.5 approximately 14 irrigations

Duration

91 days

Irrigation interval = ----- =

----- = 6.5 days = 7.0

No. of irrigation

14

## Water Management including Micro Irrigation

Water requirement for early growth period

February	March	Total
67	110	117

$$\begin{aligned} \text{No. of irrigation} &= \frac{117}{40} \\ &= 2.925 \\ &\approx 3 \end{aligned}$$

Approximately = 3 irrigation

$$\text{Irrigation interval} = \frac{117}{3} = 39 \text{ days interval}$$

This interval is too long and the rooting depth is also very shallow during this period. Hence adjustment can be made by reducing the irrigation depth as follows

i.e., instead of 40 mm depth 30 mm depth can be tried

$$\begin{aligned} \frac{117}{30} &= 3.9 = 4 \\ \frac{117}{40} &= 2.925 = 3 \end{aligned}$$

3 days is irrigation interval can be adopted.

### IV. System as a whole approach

#### A) Rotational water supply

R.W.S is one of the techniques in irrigation water distribution management. It aims at equi-distribution of irrigation water irrespective of location of the land in the command area by enforcing irrigation time schedules.

## Water Management including Micro Irrigation

Each 10 ha block is divided into 3 to 4 sub units (irrigation groups) According to the availability of irrigation water, stabilized field channels and group-wise irrigation requirement, time schedules are evolved. The irrigation will be done strictly in accordance with the group-wise time schedules by the block committees. Within the group, the time is to be shared by the farmers themselves.

Agrifair

## 09. WATER USE EFFICIENCY (WUE) & INDICES

An efficient irrigation system implies effective transfer of water from the source to the field with minimum possible loss. The objective of the efficiency concept is to identify the nature of water loss and to decide the type of improvements in the system. Evaluation of performance in terms of efficiency is prerequisite for proper use of irrigation water.

### 1. Irrigation Efficiency

It is defined as the ratio of water output to the water input, i.e., the ratio or percentage of the irrigation water consumed by the crop of an irrigated farm, field or project to the water delivered from the source.

$$E_i = \frac{W_c}{W_r} \times 100$$

where,

$E_i$  = irrigation efficiency (%)

$W_c$  = irrigation water consumed by crop during its growth period in an irrigation project.

$W_r$  = water delivered from canals during the growth period of crops.

In most irrigation projects, the irrigation efficiency ranges between 12 to 34 %.

### 2. Water Conveyance Efficiency

It is a measure of efficiency of water conveyance system from canal network to watercourses and field channels. It is the ratio of water delivered infields at the outlet head to that diverted into the canal system from the river or reservoir. Water losses occur in conveyance from the point of diversion till it reaches the farmer's fields which can be evaluated by water conveyance efficiency, as under:

$$E_c = \frac{W_t}{W_f} \times 100$$

where,

$E_c$  = water conveyance efficiency, per cent

$W_f$  = water delivered to the farm by conveyance system (at field supply channel)

$W_t$  = water introduced into the conveyance system from the point of diversion

Water conveyance efficiency is generally low; about 21% losses occur in earthen watercourses only.

### 3. Water Application Efficiency

It is a measure of efficiency of water application in the field. It is the ratio of volume of water that is stored in the root zone of crops and ultimately consumed by transpiration or evaporation or both to the volume of water actually delivered at the field. Alternatively, it may be defined as the percentage of water applied that can be accounted for as increase in soil moisture in soils as occupied by the principal rooting system of the crop. It is also termed as farm efficiency as it takes into account water lost in application at the farm. We have

$$E_a = \frac{W_s}{W_f} \times 100$$

where,

$E_a$  = water application efficiency, per cent

$W_s$  = irrigation water stored in the root zone of farm soil

$W_f$  = irrigation water delivered to the farm (at field supply channel)

In general, water application efficiency decreases as the amount of water during each irrigation increases. Water losses due to inefficient application of water in the field vary from 28 to 50 %.

Common sources of loss of irrigation water during application are represented thus:

$R_f$  = surface runoff from the farm

$D_f$  = deep percolation below the farm root zone soil

Neglecting evaporation losses during application, we have

$$W_f = W_s + D_f + R_f$$

$$E_c = W_f - \frac{(D_f + R_f)}{W_f} \times 100$$

#### 4. Water Use Efficiency

Having conveyed water to the point of use and having applied it, the next efficiency concept of concern is the efficiency of water use. It is expressed in kg/ha cm. The proportion of water delivered and beneficially used on the project can be calculated using the following formula

$$E_u = \frac{W_u}{W_d} \times 100$$

where,

$E_u$  = water use efficiency, per cent

$W_u$  = water beneficially used

$W_d$  = water delivered

Water use efficiency is also defined as (i) **crop water use efficiency** and (ii) **field water efficiency**.

**(a) Crop Water Use Efficiency:** It is the ratio of yield of crop (Y) to the amount of water depleted by crop in evapotranspiration (ET).

$$CWUE = \frac{Y}{ET}$$

where,

CWUE = Crop water use efficiency

Y = Crop yield

## Water Management including Micro Irrigation

ET = Evapotranspiration

CWUE is otherwise called consumptive water use efficiency. It is the ratio of crop yield (Y) to the sum of the amount of water taken up and used for crop growth (G), evaporated directly from the soil surface (E) and transpired through foliage (T) or consumptive use (Cu)

$$\text{CWUE} = \frac{Y}{G+E+T}$$

where,

$$(G + E + T) = \text{Cu}$$

In other words ET is Cu since water used for crop growth is negligible.

$$\text{CWUE} = \frac{Y}{\text{CU}}$$

It is expressed in kg/ha/mm or kg/ha/cm.

### (b) Field Water Use Efficiency:

It is the ratio of yield of crop (Y) to the total amount of water used in the field.

$$\text{FWUE} = \frac{Y}{\text{WR}}$$

where,

FWUE = field water use efficiency

WR = water requirement

This is the ratio of crop yield to the amount of water used in the field (WR) including growth (G), direct evaporation from the soil surface (E), transpiration (T) and deep percolation loss (D).

Y

## Water Management including Micro Irrigation

$$FWUE = \frac{\text{Crop yield}}{\text{G+E+T+D}}$$

$$\text{G+E+T+D}$$

$$\text{G+E+T+D} = WR$$

It is expressed in kg/ha/mm (or) kg/ha/cm

Deep percolation is important for rice crop. For other crops seepage is important.

Of the two indices defined, the crop water use efficiency is more of research value whereas the field water use efficiency has greater practical importance for planners and farmers.

### 5. Water Storage Efficiency:

It is defined as the ratio of the water stored in the root depth by irrigation to the water needed in the root depth to bring it to the field capacity. Also termed as water storage factor.

$$Es = \frac{Ws}{Ww} \times 100$$

where,

Es = water storage efficiency, per cent

Ws = water stored in the root zone during the irrigation

Ww = water needed in the root zone prior to irrigation, i.e., field capacity available moisture.

### 6. Water Distribution Efficiency

Expression for distribution efficiency to evaluate the extent to which the water is uniformly distributed is as follows:

$$Ed = \frac{(1-d)}{D} \times 100$$

$$\begin{aligned} & (1 - \text{Average deviation}) \\ & = \frac{\text{-----}}{100 \text{ Average depth applied}} \times X \end{aligned}$$

where,

Ed = water distribution efficiency, per cent

d = average numerical deviation in depth of water stored from average depth stored during irrigation

D = average depth of water stored along the run during irrigation

A water distribution efficiency of 80% means that 10% of water was applied in excess and consequently 10% was deficient in comparison to the average depth of application.

### 7. Consumptive Use Efficiency

It is defined as the ratio of consumptive water use by the crop of irrigated farm or project and the irrigation water stored in the root zone of the soil on the farm or the project area. After irrigation water is stored in the soil, it may not be available for use by the crop because water may evaporate from the ground surface or continuously move downward beyond the root zone as it may happen in wide furrow spacing. The loss of water by deep penetration and by surface evaporation following irrigation is evaluated from the following expression:

$$E_{cu} = \frac{W_{cu}}{W_d} \times 100$$

where,

E<sub>cu</sub> = consumptive use efficiency, per cent

W<sub>cu</sub> = normal consumptive use of water

W<sub>d</sub> = net amount of water depleted from root zone soil

## Water Management including Micro Irrigation

Consumptive use efficiency is useful in explaining the difference in crop response from different methods of irrigation.

### Exercise

1. Work out the irrigation efficiency from the following data.

Water conveyance and delivery loss	=	40%
Deep percolation and surface runoff in farms	=	30%
Water stored in soil lost by evaporation	=	20%

2. A borewell fitted with 7.5 HP motor discharges water at the rate of 12 lit/sec. Water received at the main field. Channel was measured as 8.5 lit/sec. Workout the conveyance efficiency.
3. Work out the water use efficiency for the following crops using the data given in the table.

Crop	Yield (kg/ha)	ET (mm)	WR (mm)
Rice	6,200	500	1,200
Groundnut	800	320	500
Sugarcane	110,000	1,260	2,050

## **10. AGRONOMIC PRACTICES FOR USE OF PROBLEM WATER - SALINE, EFFLUENT, SEWAGE WATER**

### **Quality of irrigation water**

Whatever may be the source of irrigation water viz., river, canal, tank, open well or tube well, some soluble salts are always dissolved in it. The main soluble constituent in water are Ca, Mg, Na and K as cations and chloride, sulphate bicarbonate and carbonate as anions. However ions of other elements such as lithium, silicon, bromine, iodine, copper, cobalt, fluorine, boron, titanium, vanadium, barium, arsenic, antimony, beryllium, chromium, manganese, lead, selenium phosphate and organic matter are also present. Among the soluble constituents, calcium, sodium, sulphate, bicarbonate and boron are important in determining the quality of irrigation water and its suitability for irrigation purposes. However other factors such as soil texture, permeability, drainage, type of crop etc., are equally important in determining the suitability of irrigation water. The following are the most common problems that result from using poor quality water.

#### **1. Salinity**

If the total quantity of salts in the irrigation water is high, the salts will accumulate in the crop root zone and affect the crop growth and yield. Excess salt condition reduces uptake of water due to high concentration of soil solution.

#### **2. Permeability**

Some specific salts reduce the rate of infiltration in to the soil profile

#### **3. Toxicity**

When certain constituents of water are taken up by plants which accumulates in large quantities and results in plant toxicity and reduces yield.

#### **4. Miscellaneous**

Excessive Nitrogen in irrigation water causes excessive vegetative growth and leads to lodging and delayed crop maturity. White deposits on fruits or leaves may occur due to sprinkler irrigation with high bicarbonate water.

**Classification of irrigation water quality**

Quality of water	EC (m.mhos / cm)	pH	Na (%)	Cl (me/l)	SAR
Excellent	0.5	6.5 – 7.5	30	2.5	1.0
Good	0.5 – 1.5	7.5 – 8.0	30–60	2.5 – 5.0	1.0 – 2.0
Fair	1.5 – 3.0	8.0 – 8.5	60–75	5.0 – 7.5	2.0 – 4.0
Poor	3.0 – 5.0	8.5 – 9.0	75–90	7.5 – 10.	4.0 – 8.0
Very poor	5.0 – 6.0	9.0 – 10.	80–90	10.0 – 12.5	8.0 – 15.0
Unsuitable	>6.0	> 10	>90	>12.5	>15

(SAR – Sodium Adsorption ratio)

**Factors affecting suitability of waters for irrigation**

The suitability of particular water for irrigation is governed by the following factors.

1. Chemical composition of water (TSS, pH; CO<sub>3</sub>, HCO<sub>3</sub>, Cl, So<sub>4</sub>, Ca, Mg, Na, and B)
2. Total concentration of soluble salts or salinity (EC)
3. Concentration of sodium ions, in proportion to calcium and magnesium or sodicity (SAR);
4. Trace element boron may be toxic to plant growth, if present in limits beyond permissible
5. The effect of salt on crop growth is of osmotic nature. If excessive quantities of soluble salts accumulate in the root zone the crop has extra difficult in extracting enough water from salty solution, thereby affecting the yields adversely.
6. Besides this, total salinity depends of the extent to which exchangeable sodium percentage (ESP) of soil increase as a result of adsorption of sodium from water. This increase depends on sodium percentage.
7. Soil characteristics like structure, texture, organic matter, nature of clay minerals, topography etc.

## Water Management including Micro Irrigation

8. Plant characteristics like tolerance of plant varies with different stages of growth. The germinating and seedling stages are usually the most sensitive to salinity.
9. Climatic factors can modify plant response to salinity. Tolerance to saline water irrigation is often greater in winter than in the summer. Rainfall is the most significant factor for the leaching of salts from the plant root zone. Temperature also plays a vital role.
10. Management practices also play great role. Wherever saline water is used for irrigation, adoption of management practices which allow minimum salt accumulation in the root zone of the soil is necessary.

The primary parameters that have to be considered to ensure effective irrigation management for salt control are the water requirement of crop and quality of irrigation water. Correct irrigation should restore any soil water deficit, to control salt levels.

Points to be considered for the management and use of poor quality water

1. Application of greater amounts of organic matter such as FYM, compost etc., to the soil to improve permeability and structure.
2. Increasing the proportion of calcium, through addition of gypsum ( $\text{CaSO}_4$ ) to the irrigation water in the channel, by keeping pebbles mixed pure gypsum bundles in the irrigation tank.
3. Mixing of good quality water with poor water in proper proportions so that both the sources of water are effectively used to maximum advantage.
4. Periodical application of organic matter and raising as well as incorporation of green manure crops in the soil.
5. Irrigating the land with small quantities of water at frequent intervals instead of large quantity at a time.

## Water Management including Micro Irrigation

6. Application of fertilizer may be increased slightly more than the normally required and preferably ammonium sulphate for nitrogen, super phosphate and Di Ammonium Phosphate (DAP) for phosphorus application
7. Drainage facilities must be improved
8. Raising of salt tolerant crops such as cotton, ragi, sugar beet, paddy, groundnut, sorghum, corn, sunflower, chillies, tobacco, onion, tomato, garden beans, amaranthus and lucerne.

### **Use of poor quality water**

Besides the salinity and alkalinity hazard of water, some industrial effluents and sewage water are also problem water that can be reused by proper treatment. The complex growth of industries and urbanization (Urban development) leads to massive increase in waste water in the form of sewage and effluent. Waste water supplies not only nutrient but also some toxic elements such as total solids of chloride, carbonate, bicarbonate, sulphate, sodium chromium, calcium magnesium, etc., in high concentration. Besides this the effluent or waste water creates BOD (Bio chemical Oxygen Demand) These waste water when used for irrigation leads to surface and sub surface source of pollution due to horizontal and vertical seepage.

### **Projected waste-water Utilization**

It is estimated that 287,000 million m<sup>3</sup> of waste water can be reusable during 2000 A.D. Hence this waste water can be properly treated as follows

- ◆ Dilute with good quality water in the ratio of 50:50 or 75:25
- ◆ Alternate irrigation with waste water and good quality water
- ◆ Treat the effluent water through fill and draw tanks, lime tank, equalization tank, settling tank, sludge removal tank, aerobic and anaerobic treatment tanks etc.,

## **11. WATER MANAGEMENT FOR PROBLEM SOILS**

When rocks and minerals under go weathering process large quantities of soluble salts are formed. In humid regions these salts are washed down to the ground water and to the sea. But in arid and semi arid regions they accumulate in the soil. Excessive irrigation and poor water management are the two chief causes of water logging and salt accumulation. An accumulation of salts in soil leads to unfavourable soil water-air relationship and effect the crop production.

The following are the main causes which leads to development of salty soils (salinity or alkalinity)

### **1. Arid climate**

About 25% of earth surface is arid in which salt accumulation is a common problem. In India about 25 million hectare is salt affected with different degree of degradation.

### **2. High subsoil water table**

When the water table is with in capillary range, the water containing soluble salts rises to surface. When the water evaporates the salts are deposited as encrustation. It is estimated that in Punjab annually about 50,000 acres becomes saline because of raising water table.

### **3. Poor drainage**

Due to poor drainage accumulation of water leads to water logging condition which leads to salt accumulation.

### **4. Quality of irrigation water**

Irrigation water containing more than permissible quantities of soluble salts with sodium carbonate and bicarbonates make the soil salty.

### **5. Inundation with sea water**

In coastal area, periodical inundation of land by sea water during high tides makes soil salty. Besides deep bore wells are also the reason for saline soils.

### 6. Nature of parent rock minerals

The saline nature of parent rock minerals leads to salt accumulation

### 7. Seepage form canals

The continuous seepage leads to salt accumulation.

### Classification of problem soils

The soil problems can also be divided into

- a) Chemical
- b) Physical

### Soil Chemical Problem

The salt affected soils can be classified based on their ESP, pH and EC as follows

	ESP (%)	EC mhos/cm	pH
Saline	< 15	> 4	< 8.5
Saline alkali	> 15	> 4	> 8.5
Alkali/sodic	> 15	< 4	> 8.5

### Reclamation of Saline soil

Leaching or flushing with good quality of water provided there will not be water logged condition i.e. good drainage system should be there to flush water.

### Reclamation of Alkali soil

By converting exchangeable sodium into soluble salts by adding the following amendments.

1. Calcium chloride
2. Calcium sulphate (Gypsum)
3. Sulphuric acid
4. Ferrous sulphate
5. Aluminum sulphate

### Reclamation of Saline alkali soil

The reclamation of these soils is similar to that of alkali soils. First step is to remove the exchangeable sodium and then the excess salts and sodium are to be leached out.

Commonly salt affected soils are referred as problem soils as indicated above. Further, based on pH value it can also be grouped as acid soils where the pH value is less than 7.

### **Management practices for chemical problems of soil**

Reclamation of saline and alkali soils are not complete unless proper remedial measures are under taken to restore the soil fertility and structure of the soil. The following are the important management practices to overcome there problems.

- ◆ The saline soil can be easily improved with leaching of salts by using of good quality water and by providing good drainage systems.
- ◆ Application of gypsum would improve the permeability of soil by making good soil aggregates
- ❖ In acidic soils, lime application should be adequate and excessive leaching should be avoided
- ◆ Salt resistant or saline resistant species should be selected for cultivation
- ◆ Application of amendments viz gypsum and press mud is found to suppress the sodium and chromium content in plant and soil.
- ◆ Growing resistant crops like ragi cotton, barley and rice can be advocated.
- ◆ Growing green manure crops like sunnhemp, daincha and kolinji can be advocated.
- ◆ Growing resistant varieties like CoC 771 in sugarcane Co 43 in rice may be made.
- ◆ Adoption of drip irrigation for possible crop is also recommended to over come soil physical and chemical problems.
- ◆ Liberal application of FYM
- ◆ Application of green manure

- ◆ Excess phosphorous and application
- ◆ Proper drainage to keep the soil without adverse effect to plant systems.

### **Soil physical problems**

Very coarse, very clayey texture, shallow depth and encrustation in soil surface are the possible physical problems. Too frequent irrigation in clayey soils with very high water retention results in poor drainage, water logging and crop damage. Excess irrigation or heavy rain create hardening of soil surface in red latritic soils with high Fe and Al hydroxides and low organic matter. This leads to poor germination, restriction of shoot and development and slow entry of water into the soil profile.

### **Water management practices for physical problem of soil**

- In light soils shallow depth of water with more frequency should be adopted.
- To increase the infiltration rate of clay type soil, breeding of soil by mixing with coarse textured soil or tank silt at the rate of 50 tones per hectare is advocated.
- Organic wastes like crop residue, farm waste, coir pith, filter cake, etc., at the rate of 20 tones per hectare once in every year can be applied.
- Poorly drained clay soils can be improved by providing tile drains and trenches intermittently.
- To make the soil more permeable and to overcome poor drainage, addition of organic wastes or sandy soil at the rate of 20 tones per ha or 50 tones per ha respectively is advocated.
- Tank silt or heavy soil application is the only way to increase soil depth and water holding capacity. Besides growth shallow rooted crop is advisable.
- The encrustation problem could be alleviated by incorporating organic matter and adding montmorilonite clay containing silt.

## 12. Water Management Technology Options for Non-Rice Crops

Special irrigation techniques for non-rice crops:

Paired row technique:

- It is a method in which accommodating crop rows on both sides of furrow by increasing ridge spacing, thereby a common furrow is used for irrigation of two rows .
- This method of irrigation has been experimented for crops like greengram, blackgram, groundnut and sunflower. The results showed that there was saving of about 20 % irrigation water and 15 % increase in crop yields
- In Coimbatore district, the paired row system of planting for cotton crop saved 29 % of irrigation water with almost the same yield as that of conventional furrow system. The water use efficiency was found to be 31.1 kg/ha-cm.

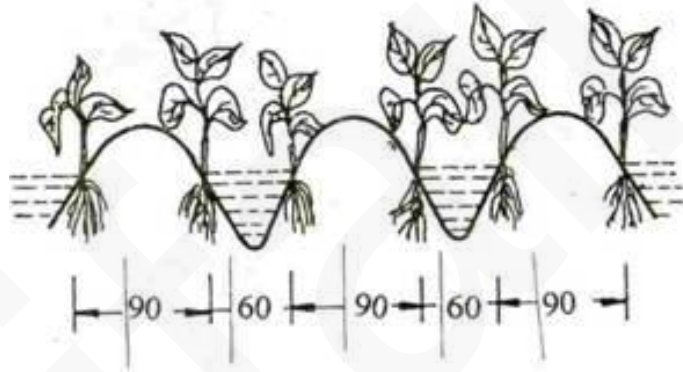

**Alternate furrow system:**

In sugarcane alternate furrow saves 34.1 % irrigation water compared to all furrow irrigation

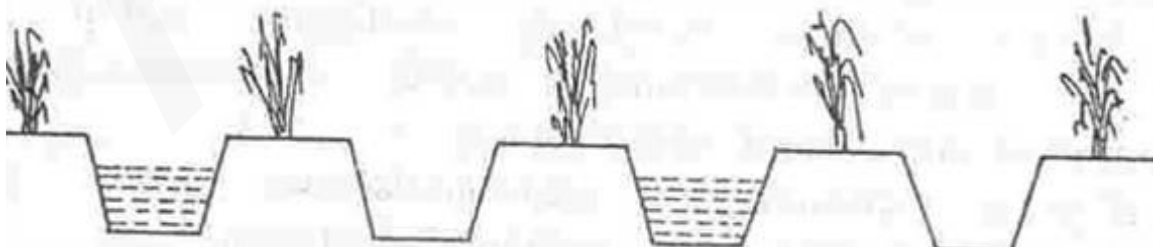

sandy clay loam soils of Coimbatore.

## Water Management including Micro Irrigation

- Growing chillies under alternate furrow irrigation with 10 t/ha of coir pith application saves 30.8 % irrigation water over all furrow irrigation.
- Growing groundnut in ridges and furrows under well irrigated conditions saves 24-27 % of irrigation water compared to check basin
- Alternate furrow irrigation to brinjal saves 24 % of water than normal farmers practice.
- Alternate furrow irrigation for PKM1 tomato crop saves 34 % of irrigation water compared to all furrow irrigation and 55.5 % over check basin. There is no significant variation in yields between the two methods

Growing turmeric under improved irrigation practice of using 5 cm depth of water plus application of coir pith 10 tons/ha as mulch saves.

Growing turmeric under improved irrigation practice of using 5 cm depth of water plus application of coir pith 10 tons/ha as mulch saves water upto 44 % over normal farmers practice (ridges and furrows).

### **Gradual widening technique**

Irrigating banana at 1.0 IW/CPE ration (once in 7 days) from 0-7 months and 1.2 IW/CPE ratio (once in 5 days) from 7-14 months recorded higher mean yield of 32.7 t/ha with an increased fruit yield of 2.1 t/ha compared to basin irrigation at 1.0 IW/CPE ratio throughout the crop growth period, besides higher WUE and saving of 140 mm of water. By gradual widening of ring basins from 30x60, 45x90 and 60x120 cm for 0-50, 51-100 and 101-150 days respectively followed. By basin method there was a saving of 25.4 % of water and increased WUE of 25.9 % over check basin

### Surge irrigation technique

A relatively new concept in surface irrigation application method viz., surge irrigation has been introduced and evaluated for field use.

Extensive experimental trails covering a wide range of long furrow specifications, inflow discharges, cycle ratios and number of surges with different test.



### Salient Features

- Easy operation and efficient manipulation of surge flow rates in accordance with the design surge cycle timing parameters and irrigation requirements.
- Deep percolation losses along furrows hardly exceed 5 % compared to more than 25 % in continuous flow systems.
- Nearly 1.5 times increase in the irrigable area per unit time
- Helps achieve high degree of irrigation efficiencies and water use efficiencies (14 kg/ha/mm of water) with maize.
- Saving in water (40 to 60 %), time and labour (30 to 45 man-hours per ha compared to more than 60 man-hours per ha in continuous flow systems

### Sorghum- Farmer's practice

- Flat bed system – irrigation based on prevailing weather and eye judgment

### Technology options

- Furrow irrigation once in 15-16 days during first 20 days of sowing and six irrigations with an interval of 6 days during the rest of the crop period
- Raton sorghum six irrigation viz., at rationing, 4-5 leaf stage, milking, soft dough and hard dough
- Surge irrigation is feasible in long furrow (>100 m) in level lands

**Pearl millet- Farmer's practice**

- Beds and channel irrigation

**Technology options**

- Irrigating with IW / CPE ratio of 0.75 at 4 cm depth was found to be optimum

**Finger millet- Farmer's practice**

- Flat bed system irrigation based on prevailing weather and eye judgment

**Technology options**

- Irrigating with IW / CPE ratio of 0.75 at 4 cm depth of water

**Maize - Farmer's practice**

- Flat bed system- irrigation based on prevailing weather and eye judgment

**Technology options**

- Irrigating the field at 10 days interval

**Pulses- Farmer's practice**

- Beds and channels and excess irrigation

**Technology options**

- Blackgram and greengram irrigation at critical stage i.e. one at sowing, second at flowering and third at pod formation with 4 cm depth.
- Irrigation once in 18 days was optimum
- Soybean, irrigation at 80 mm, CPE once in 11-12 days interval

**Groundnut -Farmer's practice**

- Beds and channel-irrigation based on prevailing weather and eye judgement

**Technology options**

- Irrigation at sowing and establishment stages and 25 DAS
- Irrigation once in 7-9 days found to be optimum

**Gingelly - Farmer's practice**

- Flat bed system and copious irrigation

### **Technology options**

- Irrigation at Flowering stage and capsule formation

### **Sunflower- Farmer's practice**

- Flat bed system

### **Technology options**

- Irrigation at IW / CPE ratio of 0.75 with 20:30:20 Kg of NPK / ha
- Surge irrigation under long furrow in level lands

### **Coconut - Farmer's practice**

- Check basin and copious irrigation

### **Technology options**

- Irrigation through drip system @ 100 litres of water / tree / day
- For stress management the palm basins to be opened to a radius of 1.8m with receipt of late showers and mulching can be done
- Husk mulching can be done to absorb rain water and making available to palm

### **Application of green manure and FYM in the basin**

- Spreading dried coconut leaves and other organic residues
- Addition of tank silt to the basin increase the water retaining capacity
- Under drought situation lower senescent leaves may be removed
- Pitcher irrigation can be followed where a little water is available

### **Cotton - Farmer's practice**

- Beds and channels

### **Technology options**

- Sowing of seeds in ridges and furrows
- Irrigation at IW / CPE ratio of 0.75
- Mulching with sugarcane trash @ 5t / ha
- Spraying of Folicot or paraffin wax 10gm or kaolin 50gm in a litre of water
- Sprinkler irrigation is feasible
- Drip irrigation can be adopted

### **Banana - Farmer's practice**

- Trench and mounds method of irrigation

### Technology options

- Irrigation at 0.75-0.9 IW /CPE ratio
- Chain basin method could be adopted
- Basins are formed around the suckers and the basins are connected through channels
- Drip irrigation with high density planting, Fertigations are preferred in favourable locations (well irrigated lands)
- Gradual widening of furrows with stage of crops.

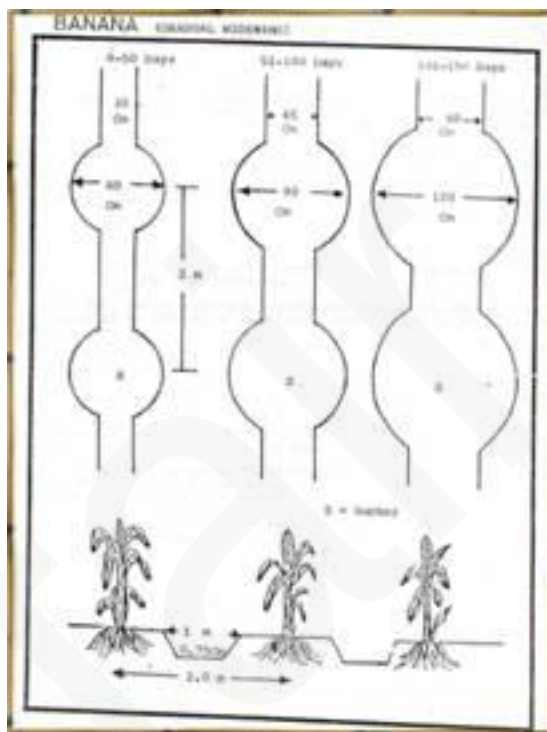

### Acid lime -Farmer's practice

- Basin irrigation

### Technology options

- Irrigation through drippers at 75 per cent of water supplied through basins
- Drip irrigation is preferred

### Tomato- Farmer's practice

- Beds and channels

### Technology options

- Furrow irrigation may be recommended
- Drip irrigation especially with micro sprinklers may also be recommended for hybrids
- Irrigation at IW / CPE ratio of 1.00 during fruit formation And ripening

## Water Management including Micro Irrigation

- Sprinkler irrigation in tomato with 1760m<sup>3</sup> gave significantly higher water use efficiency than any other irrigation method

### **Sugarcane - Farmer's practice**

- Excess irrigation through ridges and furrows

### **Technology options**

- Irrigation at IW / PE ratio of 0.9
- Mulching with sugarcane trash in garden land situation reduce evaporation loss
- Foliar application of kaolin @ 12.5 Kg in 750 litres of water per hectare reduce the transpiration loss
- Removal of old dried leaves in 5-7months old crop
- Alternate or skip furrow irrigation can be followed
- Irrigate the field based on sheath moisture percentage
- In deep trench system of planting 30cm deep trenches are opened at 80cm apart, sets are planted in trenches
- Drip irrigation with fertigation is highly suitable
- Surge irrigation may be adopted in long fields in light textured soils

### **The problems of several non-system tank irrigation system**

#### **through detailed studies**

- Encroachment, siltation, soaking of supply channels resulting in poorer / no-inflow of water, pollution of tank water by tannery and dyeing factory influence (Coimbatore, Erode, Salem Districts)
- Tank chains almost disappear and their hydrologically interlinking, any improvement could revive the tank will have benefit of exploiting full tank irrigation through appropriate or selective modernisation benefit
- Owing to vagaries of man only 50-60 % of supply is realized a crop diversification strategy with non-rice crops is suggested
- De-silting for reviving the original capacity, tank fore shore, plantation to arrest the silt flow, feasibility of connecting small different tanks into the

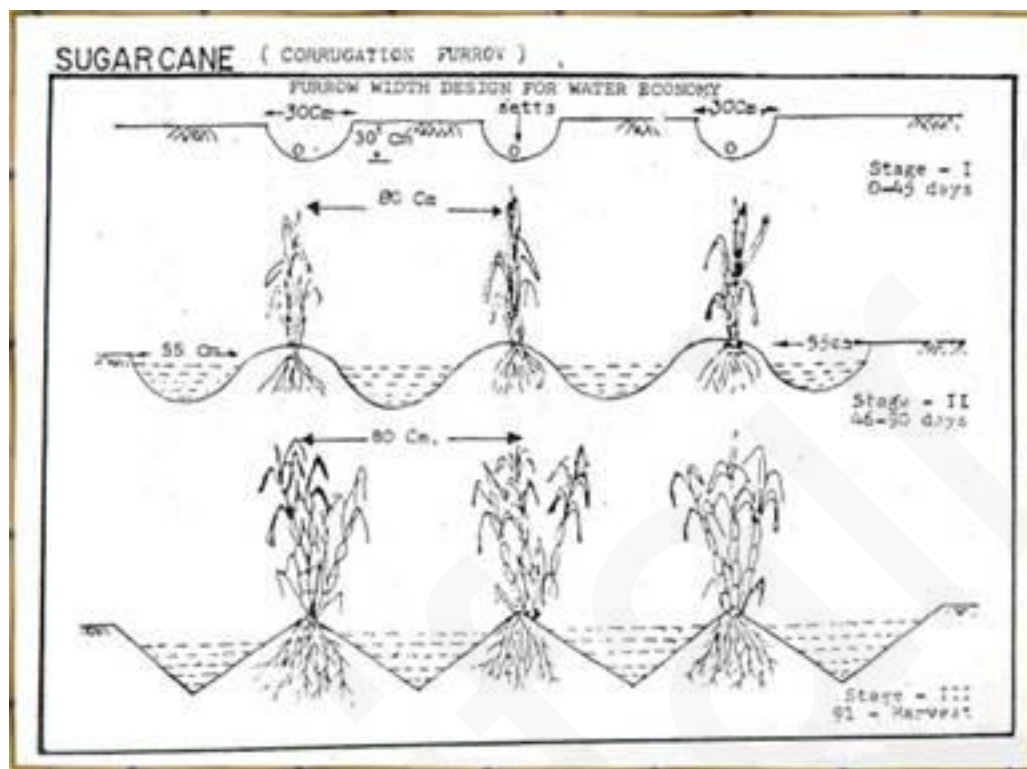

percolation pond for ground water recharge, rehabilitation of tank structure and inward channels are the solutions emanated from the tank system researches

- On-farm development structures has to be strengthened the any tank command areas for equitable water distribution from head to tail end along with farmers participation
- Other technology options for poor quality water
- Conjunctive use of relatively fresh surface water and poor quality ground water with proper proportions are recommended
- Growing of salt tolerant crops in the saline water, irrigation belt along with proper drainage facility
- Community bore wells during the period of erratic water supply in canal command areas enhanced the crop water availability and there by their yields and net returns.

### **13. COMMAND AREA DEVELOPMENT- CONTINGENT CROP PLAN IN MAJOR IRRIGATION PROJECTS OF TAMIL NADU - DRAINAGE – IMPORTANCE AND METHODS**

#### **Command Area Development**

Due to ill distribution, erratic and uncertain nature of rainfall over the year and variations is year to year cause management difficulties in predicting the quantity and scheduling irrigation in command areas. Irrigated agriculture plays a vital role in our food production and therefore a well regulated irrigation system is highly essential to reduce the loss of water and to increase irrigation efficiencies.

To achieve this maximum possible irrigation efficiencies, there are two approaches viz.,

1. Modernization of conveyance system down below the reservoirs upto government controlled outlet. This work involves mainly the construction and maintenance of head sluices, main canals, branch canals, and distributaries (Modernization of Supplier's Side or System Level Development Works)
2. Modernization below the government controlled outlets upto the drains. (Modernization of user's side or Farm level development works) This works are otherwise known as On-Farm Development works (OFD).

#### **Conveyance and distribution system**

Reservoir

Main canal

Branch canal

Minor

Distributory

Sluice / outlet

Field channel

Distribution boxes

Turnout

Checks

### **On-Farm Development Works (OFD)**

On-Farm Development works include lining of field irrigation channels and infrastructural facilities like bed regulators, diversion and distribution boxes, turnouts and drop structures to regulate and convey the irrigation water from government controlled outlets to individual land holdings.

This type of work mainly aims to reduce conveyance and application losses, to minimize water logging condition and to conserve water

Thus the OFD works are more helpful in achieving the objective of the modernization of irrigation systems.

But their execution involves lot of problems due to the following reasons

- ◆ The OFD works are to be executed in the farmers fields
- ◆ The number of farmers involved are more
- ◆ The influence of Socio-economic constraints

In Tamil Nadu, the OFD works are undertaken by the State Agricultural Engineering Department

### **The OFD Strategy**

The 10 ha. block outlets are the last government outlets having regulating shutter arrangements only at the sluices of branch canals. Each sluice serves 1 to 12 blocks through the lined distributory. The OFD works are planned duly considering the entire command area under each sluice and the irrigation problems and conflicts in each block are analysed so as to design the preventive and curative measures. The common problems prevailing in command area and the appropriate OFD measures proposed are furnished below in nutshell.

### **Problems**

- a) Absence of adequate field channel network causing wastage of irrigation in field to field irrigation.
- b) Interfering with the distributory (carrying water down to other 10 ha blocks) by adjoining head reach farmers in each block.
- c) Leakage and lateral seepage of water from earthen channels. Running at the edge of higher level lands causing “water logging” in the adjoining low lying fields.
- d) Difficulties in irrigating the higher level fields through earthen channels at zero gradient.
- e) In the locations the water need to be diverted in different wastage of land and water.
- f) Earthen channels with erosive slopes
- g) Structural deficiencies essential structures such as channel crossing, small culverts road crossings, with siphon arrangements etc., are to be constructed wherever necessary.

### **OFT measures to overcome the problems**

- a) Provision of proper earthen field channel net work to have earthen canal from the source upto each holding
- b) Provision of higher level field channels (mostly lined) parallel to the distributory in the upper part of each block for feeding to the adjoining lands without the necessity for interfering with the distributory. By this arrangement the share of lower blocks is fully allowed without any encroachment.
- c) This problem is solved by lining such portion of the earthen channels.
- d) Such earthen channels are lined at zero gradient
- e) Construction of diversion boxes with leading channels in all the required directions.
- f) Bed dams are constructed to stabilize the slope and drop structures are constructed at the point of sudden drop in bed levels.

## Water Management including Micro Irrigation

- g) Essential structures such as channel crossing, small culverts, road crossing, with siphon arrangements, etc. are constructed wherever necessary.

The above details are furnished just to show only some of the problems and relevant OFD measures. But the OFD works are carried out with the “systems approach” to provide engineering solutions for the problems in the command area with the objective of improving the irrigation water use efficiency.

### **Irrigation management under limited water supply**

As any scarce resource needs management for its optimal utility. The irrigation water also needs management to obtain optimum crop production with the available water resources. Water management is practiced in two stages. (viz)

1. Water distribution management and
2. Water utilization management. The later is the crop water management at field level.

### **Rotational Water Supply (RWS)**

RWS is one of the techniques is irrigation water distribution management. It aims at equi-distribution of irrigation water irrespective of location of the land in the command area by enforcing irrigation time schedules.

Each 10 ha. block is divided into 3 to 4 sub units (irrigation groups) According to the availability of irrigation water, stabilized field channels and group-wise irrigation requirement, time schedules are evolved. The irrigation will be done strictly in accordance with the group-wise time schedules by the block committee. Within the group, the time is to be shared by the farmers within the group by themselves.

## 14 WATER LOGGING AND FIELD DRAINAGE

For optimum growth and yield of field crops, proper balance between soil air and soil moisture is quite essential. Except rice many of the cultivated plants cannot withstand excess water in the soil. The ideal condition is that moisture and air occupy the pore spaces in equal proportions. When the soil contains excess water than that can be accommodated in the pore spaces it is said the field is water logged.

### **Causes of water logging**

1. Excessive use of water when the water is available in abundance or cheaply due to the belief that more water contributes better yield.
2. Improper selection of irrigation methods
3. Percolation and seepage from lands canals and reservoir located at nearby elevated places
4. Improper lay out and lack of outlets
5. Presence of impervious layer with profile impeding percolation
6. Upward rise of water from shallow ground water table or aquifer.

### **Effects of water logging**

#### ***Direct effects***

Replacement of soil air which is the main source of oxygen for the roots as well as soil microbes.

Due to high amount of CO<sub>2</sub> in soil air high CO<sub>2</sub> concentration under water logged condition will kill plant roots.

Sometimes superficial root system or air space in root system will develop.

Due to poor aeration intake of water and nutrient will be reduced.

#### **Indirect effects**

## Water Management including Micro Irrigation

Nutrients are made un-available due to leaching

Toxic elements will be formed under anaerobic condition

Composition of organic matter under anaerobic condition results in production of organic acids like butyric acid which is toxic to plants.

Reduces the availability of N, Mn, Fe, Cu, Zn, mb,

Reduces soil temperature

Reduces the activity of beneficial microbes

Destruct soil structure

Difficult for cultural operations

Incidence of pest, disease and weeds

### Changes for some elements in water logged condition

Elements	Normal form	Reduced form water logged soil
Carbon	Carbon di oxide	Methane (H <sub>4</sub> ) complex aldehyde
Nitrogen	Nitrate NO <sub>3</sub>	Nitrogen (N) and NH <sub>2</sub> amides, ammonia
Sulphur	Sulphate SO <sub>4</sub>	Hydrogen sulphide (H <sub>2</sub> S)

### Drainage

It is the process of removal of excess water as free or gravitational water from the surface and the sub surface of farm lands with a view to avoid water logging and creates favourable soil conditions for optimum plant growth.

### Need for drainage

It is generally assumed that in arid region drainage is not necessary and water logging is not a problem. Even in arid region due to over irrigation and seepage from reservoirs canals etc., drainage becomes necessary.

Irrigation and drainage are complementary practices in arid region to have optimum soil water balance.

## Water Management including Micro Irrigation

In humid region drainage is of greater necessity mainly due to heavy precipitation.

Drainage is required under the following condition

- a) High water table
- b) Water ponding on the surface for longer periods
- c) Excessive soil moisture content above F.C, not draining easily as in clay soil
- d) Areas of salinity and alkalinity where annual evaporation exceeds rainfall and capillary rise of ground water occurs
- e) Humid region with continuous or intermittent heavy rainfall
- f) Flat land with fine texture soil
- g) Low lying flat areas surrounded by hills

### **Characteristics of good drainage system**

1. It should be permanent
2. It must have adequate capacity to drain the area completely
3. There should be minimum interference with cultural operations
4. There should be minimum loss of cultivable area
5. It should intercept or collect water and remove it quickly within shorter period

### **Methods of drainage**

There are two methods

1. Surface method
2. Sub surface method

### **Surface drainage**

This is designed primarily to remove excess water from the surface of soil profile. This can be done by developing slope in the land so that excess water drains by gravity.

### **It is suitable for**

- (i) Slowly permeable clay and shallow soil

- (ii) Regions of high intensity rainfall
- (iii) To fields where adequate out lets are not available
- (iv) The land with less than 1.5% slope

### **It can be made by**

- a) Land smoothing
- b) Making field ditches

### **The surface drainage can be further classified as**

- a) Life drainage
- b) Gravity drainage
- c) Field surface drainage
- d) Ditch drainage

### **Lift drainage**

To drain from low lying area or areas having water due to embankment, life drainage is used. Water to be drained is lifted normally by opened devices unscoops or by pumping or by mechanical means. This method is costly, cumbersome and time consuming but effective and efficient to drain standing water over the soil surface.

### **Gravity drainage**

Water is allowed to drain from the areas under higher elevation to lower reaches through the regulated gravity flow through the out let of various types. This system is practiced in wet land rice with gentle to moderate slope.

This method is less costly, easy and effective however the area to be drained should be leveled smooth and slightly elevated from the drainage source.

### **Field surface drainage**

The excess water received from the rain or irrigation is drained through this method. The irrigated basins or furrows are connected with the drainage under lower elevation which is connected to the main out let and to the farm pond used for water harvesting. If the slope of the land is sufficient to drain excess water from the individual plot, this drain water may be collected and stored locally in reservoir for recycling for life

saving irrigation. This drainage method is cheap and effective but there is possibility of soil erosion and distribution of weed seeds along the flow of drainage water.

### **Ditch drainage**

Ditches of different dimension are constructed at distances to drain the excess water accumulated on the surface and inside the soil upto the depth of ditch. Such ditches may be interceptors or relief drains. This method is adopted in nurseries, seed beds and rainfed crops. This is an effective and efficient method but requires smoothening of surface and construction of ditches. This involves cost and wastage of crop lands. Shifting of soil, restriction for the movement of farm machineries reconstruction and renovation of ditches during the crop duration and harvesting of crops and the problems in this method. In flat land, bed or parallel field ditches may be constructed. The collector ditches should be across the field ditches.

#### **Advantages**

Low initial cost

Easy for inspection

Effective in low

Permeability area

#### **Disadvantages**

Low efficiency

Loss of cultivable land

Interference to cultural operation

High maintenance cost

### **Sub surface drainage system**

Sub surface drains are under ground artificial channels through which excess water may flow to a suitable outlet. The purpose is to lower the ground water level below the root zone of the crop. The movement of water into sub surface drains is influenced by

1. The hydraulic conductivity of soil
2. Depth of drain below ground surface
3. The horizontal distance between individual drains

Underground drainage is mostly needed to the

Medium textured soil

High value crop

High soil productivity

There are four types of sub surface drainage

1. Tile drainage
2. Mole drainage
3. Vertical drainage
4. Well Drainage / or Drainage wells

### **Advantage of sub surface**

1. There is no loss of cultivable land
2. No interference for field operation
3. Maintenance cost is less
4. Effectively drains sub soil and creates better soil environments

### **Disadvantage**

1. Initial cost is high
2. It requires constant attention
3. It is effective for soils having low permeability

### **1. Title drainage**

This consists of a continuous line of tiles laid at a specific depth and grade so that the excess water enters through the tiles and flows out by gravity. Laterals collect water from the soil and drain into sub mains and then to the main and finally to the out let. Tile drains are made with clay and concrete, tiles should be strong enough to withstand the pressure and also resistant to the erosive action of chemicals in soil water.

### **2. Mole drainage**

Mole drains are unlined circular earthen channels formed within the soil by a mole plough. The mole plough has a long blade like shank to which a cylindrical bullet nosed plug is attached known as mole. As the plough is drawn through the soil the mole forms the cavity to a set depth. Mole drainage is not effective in the loose soil since the

channels produced by the mole will collapse. This is also not suitable for heavy plastic soil where mole seals the soil to the movement of water.

### 3. Vertical drainage

Vertical drainage is the disposal of drainage water through well into porous layers of earth. Such a layer must be capable of taking large volume of water rapidly. Such layers are found in river bed.

### 4. Drainage wells

The wells are used for the drainage of agricultural lands especially in irrigated areas.

### Systems of drainage

There are five systems of drainage

1. Random
2. Herringbone
3. Grid iron
4. Interceptor

#### 1. Random

This is used where the wet area are scattered and isolated from each other. The lines are laid more or less at random to drain these wet areas. The main is located in the largest natural depression while the submains and laterals extend to the individual wet areas.

#### 2. Herring bone

In this system the main are in a narrow depression and the laterals enter the main from both side at an angle of  $45^{\circ}$  like the bones of a fish.

#### 3. Gridiron

The gridiron is similar to herringbone but the laterals enter the main only from one side at right angles. It is adopted in flat regularly shaped fields. This is an efficient drainage system.

### **4. Interceptor**

Ditches of different dimension are constructed at distance to drain the excess water accumulated on the surface and inside the soil upto the depth of ditch. Such ditches may be interceptors or relief drains. This method is adopted in nurseries, seed beds and rainfed crops. This is an effective and efficient method but requires smoothing of surface and construction of ditches. This involves cost and wastage of crop lands. Shifting of soil, restriction for the movement of farm machineries reconstruction and renovation of ditches during the crop duration and harvesting of crops are the problems in this method. In flat land, bed or parallel field ditches may be constructed. The collector ditches should be across the field ditches.

## **DRIP IRRIGATION AND FERTIGATION**

### **DRIP IRRIGATION SYSTEM**

#### **INTRODUCTION**

Drip irrigation refers to application of water in small quantity at the rate of mostly less than 12 lph as drops to the zone of the plants through a network of plastic pipes fitted with emitters. Drip irrigation in its present form has become compatible with plastics that are durable and easily moulded into a variety and complexity of shapes required for pipe and emitters.

#### **MERITS**

1. Increased water use efficiency
2. Better crop yield
3. Uniform and better quality of the produce
4. Efficient and economic use of fertiliser through fertigation
5. Less weed growth
6. Minimum damage to the soil structure
7. Avoidance of leaf burn due to saline soil
8. Usage in undulating areas and slow permeable soil
9. Low energy requirement (i.e.) labour saving
10. High uniformity suitable for automation

#### **DEMERITS**

1. Clogging of drippers
2. Chemical precipitation
3. Salt accumulation at wetting front

### **COMPONENTS AND ITS SELECTION FOR A TYPICAL DRIP IRRIGATION**

#### **LAYOUT**

#### **HEAD EQUIPMENTS**

- |                           |   |  |
|---------------------------|---|--|
| a. Water source           | - | Subsurface tank  |
| b. Pump                   | - | Suction, monoblock pump, delivery non return valve, gate valve |
| c. Filter station         | - | Sand filter, screen filter, manifold and pressure gauge        |
| d. Fertiliser application | - | Fertiliser tank and ventury assembly                           |

**DISTRIBUTION SYSTEM**

- e. Conveyance line - Main line, sub main, gromet take off assembly, laterals, minor tubes and end caps.
- f. Drippers - Pressure **corresponding** drippers (moulded/threaded type)
- g, Valves - Non-return valve (NRV), Ball valves, Air release valve (ARV), flush valves
- h. Water meter - If necessary
- i. Water source

**a. WATER SOURCE SUBSURFACE TANK**

To minimise the energy requirement and also to get a uniform or constant level of water owing to the accumulation of bore wells in one part of the irrigation regime; keeping in the effective hydraulic DIS design, it is necessary to construct a subsurface tank in an elevation point at the centre. The capacity of the tank is calculated from the water requirement of the crop, dripper capacity, type of soil etc.

**b. PUMP**

**Pump/Overhead Tank:** It is required to provide sufficient pressure in the system. Centrifugal pumps are generally used for low pressure trickle systems. Overhead tanks can be used for small areas or orchard crops with comparatively lesser water requirements.

1. **Filters:** The hazard of blocking or clogging necessitates the use of filters for efficient and trouble free operation of the microirrigation system. The different types of filters used in microirrigation system are described below.

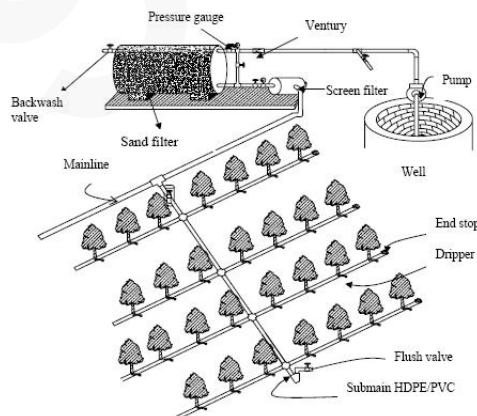

**Fig. 1.1 Components of Microirrigation System**

a) **Gravel or Media Filter:** Media filters consist of fine gravel or coarse quartz sand, of selected sizes (usually 1.5 – 4 mm in diameter) free of calcium carbonate placed in a cylindrical tank. These filters are effective in removing light suspended materials, such as algae and other organic materials, fine sand and silt particles. This type of filtration is essential for primary filtration of irrigation water from open water reservoirs, canals or reservoirs in which algae may develop. Water is introduced at the top, while a layer of coarse gravel is put near the outlet bottom. Reversing the direction of flow and opening the water drainage valve cleans the filter. Pressure gauges are placed at the inlet and at the outlet ends of the filter to measure the head loss across the filter. If the head loss exceeds more than 30 kPa, filter needs back washing. Fig. 1.2 shows different types of media filters.



**Fig. 1.2 Different types of Media filters**

b) **Screen Filters:** Screen filters are always installed for final filtration as an additional safeguard against clogging. While majority of impurities are filtered by sand filter, minute sand particles and other small impurities pass through it. The screen filter, containing screen strainer, which filters physical impurities and allows only clean water to enter into the micro irrigation system (Fig. 1.3). The screens are usually cylindrical and made of non-corrosive metal or plastic material. These are available in a wide variety of types and flow rate capacities with screen sizes ranging from 20

mesh to 200 mesh. The aperture size of the screen opening should be between one seventh and one tenth of the orifice size of emission devices used.



**Fig.1.3 Screen filter showing steel wire mesh strainers**

- c) **Centrifugal Filters:** Centrifugal filters are effective in filtering sand, fine gravel and other high density materials from well or river water. Water is introduced tangentially at the top of a cone and creates a circular motion resulting in a centrifugal force, which throws the heavy suspended particles against the walls. The separated particles are collected in the narrow collecting vessel at the bottom. Fig.1.4 shows different types hydro cyclone/centrifugal filters.



**Fig.1.4 Hydro cyclone filter**

- d) **Disk Filters:** Disk filter (Fig. 1.5) contains stacks of grooved, ring shaped disks that capture debris and are very effective in the filtration of organic material and algae. During the filtration mode, the disks are pressed together. There is an angle in the alignment of two adjacent disks, resulting in cavities of varying size and partly turbulent flow. The sizes of the groove determine the filtration grade. Disk filters are available in a wide size range (25-400 microns). Back flushing can clean disk filters. However they require back flushing pressure as high as 2 to 3 kg/cm<sup>2</sup>.



**Fig.1.5 Disk filter showing stacks of discs**

4. **Pressure relief valves, regulators or bye pass arrangement:** These valves may be installed at any point where possibility exists for excessively high pressures, either static or surge pressures to occur. A bye pass arrangement is simplest and cost effective means to avoid problems of high pressures instead of using costly pressure relief valves.
5. **Check valves or non-return valves:** These valves are used to prevent unwanted flow reversal. They are used to prevent damaging back flow from the system to avoid return flow of chemicals and fertilizers from the system into the water source itself to avoid contamination of water source.

**Distribution Network:**

It mainly constitutes main line, submains line and laterals with drippers and other accessories.

**1. Mainline**

The mainline transports water within the field and distribute to submains. Mainline is made of rigid PVC and High Density Polyethylene (HDPE). Pipelines of 65 mm diameter and above with a pressure rating 4 to 6 kg/cm<sup>2</sup> are used for main pipes.

**2. Submains**

Submains distribute water evenly to a number of lateral lines. For sub main pipes, rigid PVC, HDPE or LDPE (Low Density Polyethylene) of diameter ranging from 32 mm to 75 mm having pressure rating of 2.5 kg/cm<sup>2</sup> are used.

**3. Laterals**

Laterals distribute the water uniformly along their length by means of drippers or emitters. These are normally manufactured from LDPE and LLDPE. Generally pipes having 10, 12 and 16 mm internal diameter with wall thickness varying from 1 to 3 mm are used as laterals.

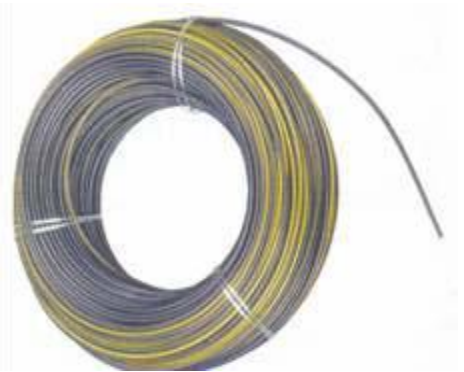

#### 4. Emitters / Drippers

They function as energy dissipaters, reducing the inlet pressure head (0.5 to 1.5 atmospheres) to zero atmospheres at the outlet. The commonly used drippers are online pressure compensating or online non-pressure compensating, in-line dripper, adjustable discharge type drippers, vortex type drippers and micro tubing of 1 to 4 mm diameter. These are manufactured from Poly- propylene or LLDPE.

##### A) Online Pressure Compensating drippers:

A pressure compensating type dripper supplies water uniformly on long rows and on uneven slopes. These are manufactured with high quality flexible rubber diaphragm or disc inside the emitter that it changes shape according to operating pressure and delivers uniform discharge. These are most suitable on slopes and difficult topographic terrains.



##### B) Online Non-Pressure Compensating drippers:

In such type of drippers discharge tends to vary with operating pressure. They have simple thread type, labyrinth type, zigzag path, vortex type flow path or have float type arrangement to dissipate energy. However they are cheap and available in affordable price.



### C) In-Line Drippers or Inline tubes:

These are fixed along with the line, i.e., the pipe is cut and dripper is fixed in between the cut ends, such that it makes a continuous row after fixing the dripper. They have generally a simple thread type or labyrinth type flow path. Such types of drippers are suitable for row crops.

Inline tubes are available which include inline tube with cylindrical dripper, inline tubes with patch drippers, or porous tapes or biwall tubes. They are provided with independent pressure compensating water discharge mechanism and extremely wide water passage to prevent clogging.



Other accessories are take-out/starter, rubber grommet, end plug, joints, tees, manifolds etc.

## INSTALLATION, OPERATION OF DRIP IRRIGATION SYSTEM

The installation of the drip system be divided into 3 stages.

1. Fitting of head equipments
2. Connecting mains and sub mains
3. Laying of lateral with drippers.

### 3.1. INSTALLATION OF HEAD EQUIPMENTS

The following points should be considered for fixing the position of filter station.

1. Minimum use of fitting such as elbows and bends to be made
2. Whether the pump delivery can be connected to the sand / screen filter
3. Sand / screen filter can easily be connected to mainline
4. Arrangement of back-wash to be made as per the farmer's suitability
5. Arrangement of by-pass water to be made

AgriFair

6. Sufficient space to be provided for the easy operation of filter valves
7. Hard surface or cement concrete foundation to be made for sand filter so that it will not collapse due to vibration and load. For screen filter, provide strong support by using GI fittings to avoid its vibrations due to load
8. Use hold-tight over the threads of GI fittings and apply proper mixture of M-seal over the joints uniformly to avoid leakage
9. Fix the pressure gauges in inlet and outlet of the filter
10. Avoid direct linking of oil pump delivery and filter. Instead connect the filter to the pump delivery using flanges or even the hose pipe can be used for this

### **3.2. CONNECTING MAINS AND SUB MAINS**

1. It should be laid at a depth of more than 30 - 45 cm so as to avoid damages during intercultivation
2. Remove mud, if any, in the pipes before fitting. These pipes can be fitted using solvent cement with the help of brush
3. A gunmetal gate valve / PP Ball valve is provided at the start of sub main with PVC MTA fittings for connecting the valve in the PVC sub main
4. Provide flush valve at the end of main and sub main such that it faces towards slope
5. Apply uniform pressure vertically over the drill while drilling in the sub main so that the hole will be smooth and round.
6. Fix the rubber grommets in the holes made in the sub main in such a way that the groove in it goes inside the pipe
7. Fix the take-off position such that its arrow or the chamber faces towards the gate valve of the sub main for the easy flow of water. See that the take-off is fixed tightly in the grommet. The loose fitting of take-off indicates the breakage of grommet
8. Get the sub main flushed so that the PVC piece / mud fallen in the sub main while making drill will get flushed. Otherwise this scrap will block the drippers through polytube

### **3.3. LAYING OF LATERALS AND DRIPPERS**

1. Pass water through the poly tube and get it flushed so that it gets bulged and makes easy for punching
2. Punch the lateral sideway from the yellow strip

3. The dripper position should be fixed according to design, soil and water report and water level in peak summer
4. If two drippers are to be provided such that all the drippers come in a straight line
5. Do not fix drippers unless a complete lateral line is punched. Otherwise the placement of drippers will be changed if moved
6. Punching should be done from the sub main
7. While fixing the dripper, push it inside the lateral and pull it slightly
8. Close the end of lateral by fitting end cap

#### **4. STANDARD PROCEDURE FOR ASSESSING DIS PERFORMANCE**

1. Check installation according to approved design layout
2. Start the pump
3. Flush the filters
4. Allow the drip system to be loaded with water for 10 min.
5. Note the pressure from the pressure gauge at the inlet and outlet of sand and screen filters
6. Record the dripper discharge as per the format
7. The discharge and pressure readings have to be taken in the below mentioned locations
  - a. First, Middle and Last Dripper of a lateral
  - b. For laterals at beginning,  $\frac{1}{4}$ ,  $\frac{1}{2}$ ,  $\frac{3}{4}$  and end of sub main
8. Laterals on anyone side of the sub main can be selected in case of plain land or alternative laterals on either side in case of slight slope in the direction along the lateral
9. Measure the volume of water collected for 36 seconds
10. Measure the pressure at start and end of laterals
11. If the Emission Uniformity is less than 85 % then the issue has to be taken up with the Drip Irrigation System Designer
12. Modifications have to be taken accordingly

## FERTIGATION

### FERTILISER APPLICATOR

This is the process of applying fertilisers through the irrigation system. The soil is negatively charged at high pH and  $\text{PO}_4^-$  will be precipitated with  $\text{Ca}^+$  and absorbed with clay. Availability of P is very low as time proceeds due to this precipitation. Fertigation is problematic at high pH because the availability of micronutrients (Fe, Mn, etc.) is less due to the precipitation. Hence iron chelates (Sequestrene -138) are applied which prevents Fe from precipitation. Also zinc chelates are good to prevent Zn precipitation.

### ADVANTAGES

1. Eliminates manual application
2. Quick and convenient
3. Uniformity in application
4. High efficiency and saving of fertiliser upto 30 - 40%
5. Less fertilizer leaching
6. Better penetration of P and K in the layers
7. Co-ordination of nutrition requirement with crop stage or development
8. Possibility of dosage control.
9. Others like herbicides, pesticides, acid, etc can also be applied

### LIMITATIONS

1. Toxicity to field workers
2. Chance of backflow into water source, for that NRV and vacuum valve has to be installed
3. Insoluble fertilisers are not suitable (super phosphate)
4. Corrosive effect of fertiliser
5. Phosphate may get precipitated in the pipe line and dripper due to pH reaction
6. High cost

## **FERTILISATION**

### **NITROGEN FERTILISATION**

#### **Fertiliser sources**

Nitrogen (N) being one of the major plant nutrients, is often supplied in order to obtain optimum crop production. Nitrogen availability is usually limited in the soil compared with other plant nutrients because its various forms can be leached, volatilised, denitrified or fixed in the organic fraction of the soil.

#### **WATER QUALITY INTERACTIONS WITH 'N'**

Although water quality must be considered when N is applied through a trickle irrigation system, it is less of a problem than other nutrients such as phosphorus. The injections of anhydrous ammonia or aqua ammonia into irrigation water will bring about an increase of pH that may be conducive to the precipitation of calcium, magnesium and phosphorus, or the formation of complex magnesium ammonium phosphates, which are insoluble. This can be especially serious if bicarbonate is also present in the irrigation water.

Nitrogen injected in the form of ammonium phosphate can cause serious clogging of the irrigation system. If calcium and magnesium are present in the irrigation water, the phosphate can form complex precipitates.

One of the favoured forms of N for use in this system is urea, because it is a highly soluble nitrogen fertiliser that does not react with water to form ions unless the enzyme urease is present. The enzyme, however, is often found in water containing large amounts of algae or other microorganisms. Since urease is not removed by filtration, its presence could cause hydrolysis of nitrogen in urea to the ammonium ion.

#### **PHOSPHORUS FERTILISATION**

Generally, injection of phosphorus (P) fertiliser through a trickle irrigation system has not been recommended. Most P fertilisers have created chemical or physical precipitation problems and subsequent clogging of the trickle irrigation system. Further, the fixation rate of P by soils is high and subsequent movement from its point of placement is limited.

#### **WATER QUALITY INTERACTION WITH P**

The possibility of precipitation of insoluble phosphate is extremely high in calcium and magnesium. The result is the clogging of emitters or trickle lines with calcium and/or

magnesium phosphates. However, if precautions are taken phosphoric or sulphuric acid can be added to a trickle irrigation system to prevent such problems.

### POTASSIUM FERTILIZATION

No adverse chemical reactions are expected with the common potassium (K) fertilisers when they are added alone to water. However reduced solubility and/or fertiliser incompatibility is possible when different fertiliser types are mixed. An example is a mixture of calcium nitrate and potassium sulphate, which will yield insoluble calcium sulphate.

### PLAN AND FERTILIZER SCHEDULE

The actual plan and fertilization schedule of drip irrigated crops depends on site specific conditions such as cultural practices, soil type, crop, nutrients required, amount of water to be applied, fertiliser injector and system design. Finally, a correct rate and concentration of application is desired and the same should be selected to avoid over fertigation. For perennial crops with wide spacing where the fertiliser is applied manually, it may result in a very high application rate and thus, higher concentration which may damage the plant. It will also upset the nutrient balance, change the pH' and may create toxicity.

Fertiliser application through drip irrigation may be applied through the desired or half the strength concentration. Most crop needs may be met at a concentration of 100 mg /l in the irrigated water.

Other accessories are take-out/starter, rubber grommet, end plug, joints, tees, manifolds etc.

### *Fertilizers Suitable for Fertigation*

Name	Chemical form	N-P <sub>2</sub> O <sub>5</sub> -K <sub>2</sub> O Content (%)	Solubility (g/l at 20 <sup>0</sup> C)	Remarks
Ammonium Nitrate	NH <sub>4</sub> NO <sub>3</sub>	34-0-0	1830	Incompatible with acids
Ammonium Sulfate	(NH <sub>4</sub> ) <sub>2</sub> SO <sub>4</sub>	21-0-0	760	Clogging with hard water
Urea	CO(NH <sub>2</sub> ) <sub>2</sub>	46-0-0	1100	
Diammonium Phosphate	(NH <sub>4</sub> ) <sub>2</sub> HP <sub>2</sub> O <sub>5</sub>	18-46-0	575	Contains phosphorous at high solubility
Potassium Chloride	KCl	0-0-60	347	Chloride toxic for some crops, Cheapest K source
Potassium Nitrate	KNO <sub>3</sub>	13-0-44	316	Expensive, high

				Nitrate
Potassium Sulfate	$K_2SO_4$	0-0-50	110	Excellent source of sulfur, clogging with hard water.
Phosphoric acid	$H_3PO_4$	0-52-0	457	Incompatible with Calcium

**Equipment and Methods for Fertilizer Injection:** Injection of fertilizer and other agrochemicals such as herbicides and pesticides into the drip irrigation system is done by i) By-pass pressure tank ii) Venturi system and iii) Direct injection system.

**(i) By-pass pressure tank:**

This method employs a tank into which the dry or liquid fertilizers kept. The tank is connected to the main irrigation line by means of a by-pass so that some of the irrigation water flows through the tank and dilutes the fertilizer solution. This by-pass flow is brought about by a pressure gradient between the entrance and exit of the tank, created by a permanent constriction in the line or by a control valve.



**(ii) Venturi Injector:**

A constriction in the main water flow pipe increases the water flow velocity thereby causing a pressure differential (vacuum) which is sufficient to suck fertilizer solution from an open reservoir into the water stream. The rate of injection can be regulated by means of valves. This is a simple and relatively inexpensive method of fertilizer application.



**(iii) Direct injection system:**

With this method a pump is used to inject fertilizer solution into the irrigation line. The type of pump used is dependent on the power source. The pump may be driven by an internal combustion engine, an electric motor or hydraulic pressure. The electric pump can be automatically controlled and is thus the most convenient to use. However its use is limited by the availability of electrical power. The use of a hydraulic pump, driven by the water pressure of the irrigation system, avoids this limitation. The injection rate of fertilizer solution is proportional to the flow of water in the system. A high degree of control over the injection rate is possible, no serious head loss occurs and operating cost is low. Another advantage of using hydraulic pump for fertigation is that if the flow of water stops in the irrigation system,

fertilizer injection also automatically stops. This is the most perfect equipment for accurate fertigation.

Two injection points should be provided, one before and one after the filter for fertigation. This arrangement helps in by-passing the filter if filtering is not required and thus avoids corrosion damage to the valves, filters and filter-screens or to the sand media of sand filters.

The capacity of the injection system depends on the concentration, rate and frequency of application of fertilizer solution.

### **MAINTENANCE OF DRIP IRRIGATION SYSTEM**

The maintenance of drip irrigation system is very essential for its successful functioning.

#### **SAND FILTER**

Backwash the sand filter to remove the silt and other dirt accumulated. Figure 1 shows the sand filter in normal filtration mode and in Figure 2 shows the Backwash mode.

Backwash allows the water to come out through the lid instead of backwash valve. Stir the sand in the filter bed upto filter candle without damaging them. Whatever dirt is accumulated deep inside the sand bed, will get free and goes out with the water through the lid.

- a) Backflush sand filter every day before starting the system and possibly before stopping irrigation
- b) Do not allow pressure difference across the sand filter more than 0.30 ksc
- c) Backflush at a pressure of 0.5 ksc to avoid loss of sand till clean water comes

#### **SCREEN FILTER**

Refer Figure 3. Open the flushing valve on the filter lid so that the dirt and silt will be flushed out. Open the filter and take out the filter element. Clean it in flowing water. Take out the rubber seals and clean them from both sides. Care should be taken while replacing the rubber seals, otherwise they might get out.

- a. Clean screen filter everyday
- b. Do not allow pressure difference across filter more than 0.2 ksc
- c. Open the drain valve to remove impurities before cleaning
- d. Use thin water jet / nylon brush to clean the filter element
- e. Do not use stones to rub the screen surface
- f. Check for any mechanical damage
- g. Never use the system without filter element inside filter

### **DAILY MAINTENANCE**

- a. Clean the sand and screen filters for 5 minutes before starting the system
- b. Ensure all drippers are working properly without any leakage
- c. Before stopping irrigation, backwash the sand filter for about 5 minutes

### **WEEKLY MAINTENANCE**

- a. Clean the sand filter by hand
- b. Flush the sub main by opening the flush valve for 5 minutes
- c. Flush laterals 5 numbers at a time for 5 minutes

### **MONTHLY MAINTENANCE**

- a. Treat the system with chlorine / acid.

Note: The frequency of chemical treatment depends on the degree of problem at the site.

### **CHEMICAL TREATMENT**

Clogging or plugging of drippers may be due to precipitation and accumulation of certain dissolved salts like carbonates, bicarbonates, Iron, Calcium and Manganese salts. The clogging is also due to the presence of microorganisms and the related Iron and Sulphur slimes due to algae and bacteria.

The clogging is usually avoided / cleared by chemical treatment of water. Chemical treatments commonly used in drip irrigation systems include addition of chloride and/or acid to the water supply.

### **ACID TREATMENT**

Hydrochloric Acid (HCl) is injected into drip systems at the rate suggested. The acid treatment is performed till a pH of 4 is observed and the system is shut down for 24 hours. Next day the system is flushed by opening the flush valve and lateral ends.

### **CHLORINE TREATMENT**

Chlorine treatment in the form of bleaching powder is performed to inhibit the growth of organisms like algae, bacteria. The bleaching powder is dissolved in water and this solution is injected into the system for about 30 minutes. Then the system is shut off for 24 hours. After 24 hours the lateral ends and flush valves are opened to flush out the water with impurities. Bleaching powder can directly added into the water source at a rate of 2 mg / litre or through ventury assembly.

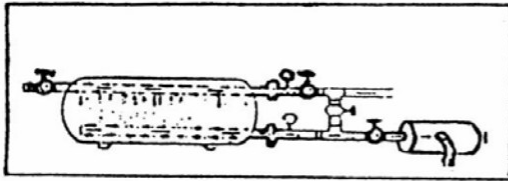

**Sand Filter: Filtration Mode**

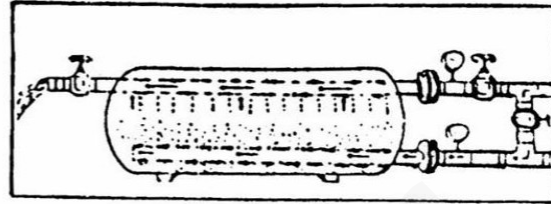

**Sand Filter: Backwash Mode**

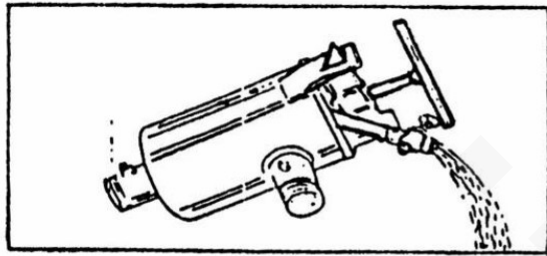

**Flushing of the Screen Filter**

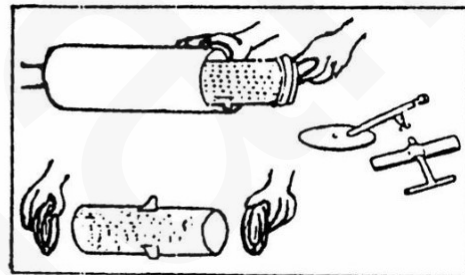

**Cleaning of Screen Filter Rubber Caps**

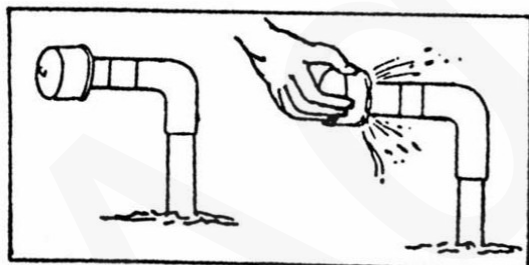

**Flushing of Sub-mains**

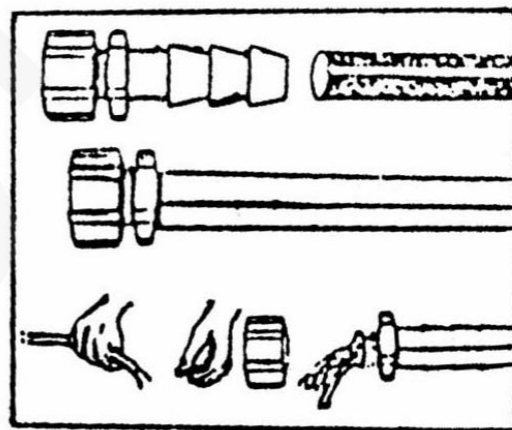

**Flushing of Lateral**

**Fig. 1.8 Maintenance of Microirrigation Components**

### **APPLICATION OF FERTILISER AND OTHER AGRO CHEMICALS**

The drip irrigation method offers an opportunity for precise application of water soluble fertilisers and other nutrients to the soils at appropriate time with the desired concentration. The development of root system is extensive in a restricted volume of soil when cultivation is done with drip irrigation and application of fertiliser or any other chemical through drip can efficiently place plant nutrients in the zone of highest root concentration. At the same time, fertiliser application presents nutrient deficiencies that can develop because of the limited soil volumes, explored by roots.

### **CRITERIA FOR APPLYING FERTILISERS THROUGH DRIP IRRIGATION SYSTEM**

All chemicals applied through irrigation systems must meet the following criteria. They must (i) avoid corrosion, softening of plastic pipe tubing, or clogging of any component of the system (ii) be safe for field use (iii) increase or at least not decrease crop yield (iv) be soluble or emulsifiable in water and (v) not react adversely to salts or other chemicals in the irrigation water. In addition, the chemicals or fertiliser must be distributed uniformly throughout the field. Achieving such uniformity of distribution requires efficient mixing, uniform water application, knowledge of the flow, characteristics of water and fertilisers in the distribution lines.

To avoid clogging, chemicals applied through drip irrigation system must meet certain requirements. The chemicals must be completely soluble. If more than one material is used in preparing a concentrated stock solution for subsequent injection into the drip lines the chemicals must not react with each other to form a precipitate. The chemicals must also be compatible with the salts contained in the irrigation water.

### **EQUIPMENT AND METHOD FOR FERTILISER INJECTION**

Fertilisers can be injected into drip irrigation systems selecting appropriate equipment from a wide assortment of available pumps, valve, tanks, venturies, meters and aspirators.

The injection points should be provided, one before and one after the filter. This arrangement can be used to bypass the filter if filtering is not required, and thus avoid corrosion damage to the valves, filters, and filter screens or to the sand media of sand filters. Furthermore, the discharge line from the fertiliser tank should have a filter, and similarly, the injection hoses line should be equipped with an in line hose filter or screen. The intake or suction side of tile injector should be equipped with a filter or strainer. Injection points must be installed so that injected fertilisers are properly mixed before the flow divides in several directions.

The size of capacity of the injection system depends on the concentration, rate and frequency of application. Naturally, less fertiliser solution and more frequent application require smaller, less costly units. Fertiliser application rates and application times vary considerably depending on crop and emitter spacing.

#### 10. DRIP IRRIGATION SYSTEM TROUBLESHOOTING

SI.No.	Problems	Causes	Remedies
1.	Leakage of water at the joint between sub main and lateral	Damaged joints	Correct damages
2.	Leakage in the poly tube	Damage of poly tube by farming activities/rat	Block the holes by Goof plug. Use poly joiners at cuts.
3.	Water not flowing upto lateral end	Holes in laterals. Cuts in laterals. Bents in laterals.	Close the holes and cuts. . Remove the bends.
4.	Out coming of white mixture on removing the end plug	More salinity in water. Uncleaned lateral	Remove the end stop. Clean the laterals fortnightly
5.	Under flow or over flow from laterals	Clogging of drippers. Unclosed end plug	Clean the sand and screen filters. Close the end cap
6.	Oily gum material comes out on opening the lateral end	More algae or ferrous material in water	Clean the laterals with water or give chemical treatment

7.	Oily gum material comes out on opening the lateral end	More algae or ferrous material in water	Clean the laterals with water or give chemical treatment
8.	More pressure drop in filters	Accumulation of dirt in filters	Clean filters every week. Back wash the filters for every 5 minutes daily.
9.	Pressure gauge not working	Rain water entry inside. Corrosion in gauge pointer damage	Provide plastic cover and fix pointer properly.
10.	Drop in pressure	Leakage in main opened outlet. Low water level in well.	Arrest the leakage and close outlet. Lower the pump with reference to well water level
11	More pressure at the entry of sand filter	No bypass in the pipeline/bypass not opened. Displacement of filter element. Less quantity of sand in filters	Provide bypass before filter and regulate pressure. Place filter element properly. Fill required quantity of sand
12.	Accumulation of sand and debris in screen filter	Displacement of filter element. Less quantity of sand in filters	Place filter element properly. Fill required quantity of sand
13.	Ventury not working during chemical treatment and fertigation	Excess pressure on filters Improper fitting of ventury assembly	Bypass extra water to reduce pressure Repair the ventury assembly.
14.	Leakage of water from air release valve.	Damaged air release valve ring.	Replace the damaged ring.

### **COST OF DRIP IRRIGATION SYSTEM:**

The cost of drip system depends on the type of crop, spacing, water requirements, proximity to water source etc. An attempt was made to prepare estimate of cost for installing drip irrigation system for all important crops by considering the cost of component supplied by the manufacturer for farmers having holdings of one acre. The cost estimation of drip system for Coconut, Amla, Banana, Tomato, Bhendi and Chilli crops are worked out and are as given below. The life of the system is about 6 to 10 years.

**COST OF MATERIALS OF DRIP IRRIGATION SYSTEM**

12 mm Lateral Pipe	-	Rs. 3.75/m
16 mm Lateral Pipe	-	Rs. 5.80/m
2" Pipe	-	Rs. 186.00/ 6 m
1 ¼" Pipe	-	Rs. 112.00/ 6 m
12 mm start, washer and end cap	-	Rs. 4.50/ 1 set
16 mm start, washer and end cap	-	Rs. 6.80/ 1 set
Emitter 4 lph, 8 lph, 16 lph (open type)	-	Rs. 2.80 each
12 mm connector	-	Rs. 1.00 each
16 mm connector	-	Rs. 1.50 each
Dummy	-	Rs. 0.30 each
2" Venturi with accessories	-	Rs. 2000 each
1 ¼" Ball valve	-	Rs. 120 each
2" Ball valve	-	Rs. 180 each
2 ½" Ball valve	-	Rs. 250 each
5 HP motor pump set	-	Rs. 10000 each
Screen Filter – 2" size	-	Rs. 2500 each
<b>Erection charges:</b>		
Coconut	-	Rs. 3 per tree
Banana	-	Rs. 0.5 per tree
Vegetables (lump sum)	-	Rs. 1000 per acre

## **SPRINKLER IRRIGATION**

### **Introduction**

In the sprinkler method of irrigation, water is sprayed into the air and allowed to fall on the ground surface somewhat resembling rainfall. The spray is developed by the flow of water under pressure through small orifices or nozzles. The pressure is usually obtained by pumping. With careful selection of nozzle sizes, operating pressure and sprinkler spacing the amount of irrigation water required to refill the crop root zone can be applied nearly uniform at the rate to suit the infiltration rate of soil.

### **Advantages of sprinkler irrigation**

- Elimination of the channels for conveyance, therefore no conveyance loss
- Suitable to all types of soil except heavy clay
- Suitable for irrigating crops where the plant population per unit area is very high.  
It is most suitable for oil seeds and other cereal and vegetable crops
- Water saving
- Closer control of water application convenient for giving light and frequent irrigation and higher water application efficiency
- Increase in yield
- Mobility of system
- May also be used for undulating area
- Saves land as no bunds etc. are required
- Influences greater conducive micro-climate
- Areas located at a higher elevation than the source can be irrigated
- Possibility of using soluble fertilizers and chemicals
- Less problem of clogging of sprinkler nozzles due to sediment laden water

### **Crop response to sprinkler**

The trials conducted in different parts of the country revealed water saving due to sprinkler system varies from 16 to 70 % over the traditional method with yield increase from 3 to 57 % in different crops and agro climatic conditions. (Table .1)

**Response of different crops to sprinkler irrigation**

Crops	Water Saving, %	Yield increase, %
Bajra	56	19
Barley	56	16
Bhindi	28	23
Cabbage	40	3
Cauliflower	35	12
Chillies	33	24
Cotton	36	50
Cowpea	19	3
Fenugreek	29	35
Garlic	28	6
Gram	69	57
Groundnut	20	40
Jowar	55	34
Lucerne	16	27
Maize	41	36
Onion	33	23
Potato	46	4
Sunflower	33	20
Wheat	35	24

Source : INCID (1998) adapted from Table 6.5

**General classification of different types of sprinkler systems**

Sprinkler systems are classified into the following two major types on the basis of the arrangement for spraying irrigation water.

1. Rotating head or revolving sprinkler system.
2. Perforated pipe system.

**1) Rotating head:**

Small size nozzles are placed on riser pipes fixed at uniform intervals along the length of the lateral pipe and the lateral pipes are usually laid on the ground surface. They may also be mounted on posts above the crop height and rotated through  $90^{\circ}$ , to irrigate a rectangular strip. In rotating type sprinklers, the most common device to rotate the sprinkler heads is with a small hammer activated by the thrust of water striking against a vane connected to it.



**Fig .1 Example of a few rotating type sprinkler irrigation systems**

**2) Perforated pipe system:**

This method consists of drilled holes or nozzles along their length through which water is sprayed under pressure. This system is usually designed for relatively low pressure ( $1 \text{ kg/cm}^2$ ). The application rate ranges from 1.25 to 5 cm per hour for various pressure and spacing.

Based on the portability, sprinkler systems are classified into the following types:

- (i) **Portable system :** A portable system has portable main lines, laterals and pumping plant

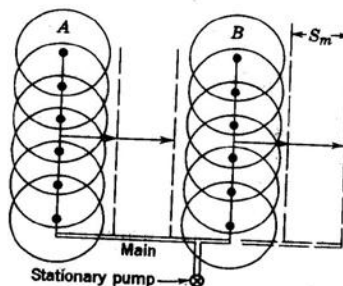

**Fig .2 Fully portable sprinkler irrigation system**

- (ii) **Semi portable system:** A semi portable system is similar to a portable system except that the location of water source and pumping plant is fixed.
- (iii) **Semi permanent system:** A semi permanent system has portable lateral lines, permanent main lines and sub mains and a stationery water source and pumping plant.
- (iv) **Solid set system:** A solid set system has enough laterals to eliminate their movement. The laterals are positions in the field early in the crop season and remain for the season.
- (v) **Permanent system:** A fully permanent system consists of permanently laid mains, sub mains and laterals and a stationery water source and pumping plant.

### Components of sprinkler irrigation system

The components of portable sprinkler system are shown through fig .3. A sprinkler system usually consists of the following components

- (i) A pump unit
- (ii) Tubings- main/submains and laterals
- (iii) Couplers
- (iv) Sprinkler head
- (v) Other accessories such as valves, bends, plugs and risers.

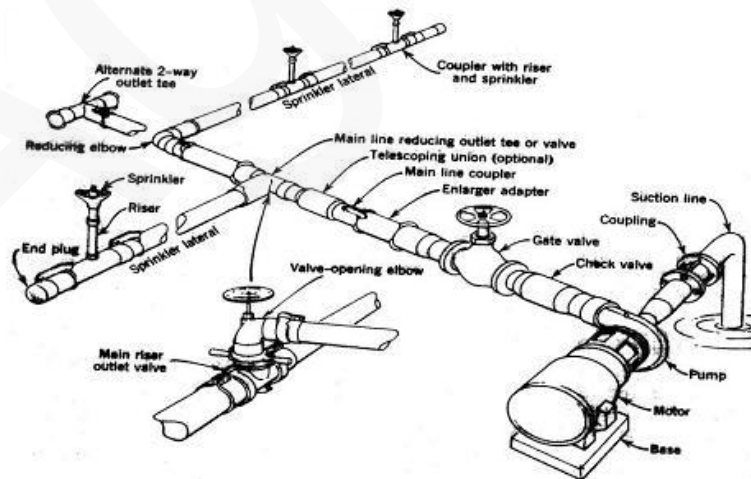

**Fig .3 Component of a portable sprinkler irrigation system**

(i) **Pumping Unit:** Sprinkler irrigation systems distribute water by spraying it over the fields. The water is pumped under pressure to the fields. The pressure forces the water through sprinklers or through perforations or nozzles in pipelines and then forms a spray. A high speed centrifugal or turbine pump can be used for operating sprinkler irrigation for individual fields. Centrifugal pump is used when the distance from the pump inlet to the water surface is less than eight meters. For pumping water from deep wells or more than eight meters, a turbine pump is suggested. The driving unit may be either an electric motor or an internal combustion engine.

(ii) **Tubings:** Mains/submains and laterals: The tubings consist of mainline, submains and laterals. Main line conveys water from the source and distributes it to the submains. The submains convey water to the laterals which in turn supply water to the sprinklers. Aluminum or PVC pipes are generally used for portable systems, while steel pipes are usually used for center-pivot laterals. Asbestos, cement, PVC and wrapped steel are usually used for buried laterals and main lines.

(iii) **Couplers:** Couplers are used for connecting two pipes and uncoupling quickly and easily. Essentially a coupler should provide

- (a) a reuse and flexible connection
- (b) not leak at the joint
- (c) be simple and easy to couple and uncouple
- (d) be light, non-corrosive, durable.

(iv) **Sprinkler Head:** Sprinkler head distribute water uniformly over the field without runoff or excessive loss due to deep percolation. Different types of sprinklers are available. They are either rotating or fixed type. The rotating type can be adapted for a wide range of application rates and spacing. They are effective with pressure of about 10 to 70 m head at the sprinkler. Pressures ranging from 16 to 40 m head are considered the most practical for most farmers.



**Fig.4 Sprinkler head**

Fixed head sprinklers are commonly used to irrigate small lawns and gardens. Perforated lateral lines are sometimes used as sprinklers. They require less pressure than rotating sprinklers. They release more water per unit area than rotating sprinklers. Hence fixed head sprinklers are adaptable for soils with high intake rate.

(v) **Fittings and accessories:** The following are some of the important fittings and accessories used in sprinkler system.

- (a) **Water meters:** It is used to measure the volume of water delivered. This is necessary to operate the system to give the required quantity of water.
- (b) **Flange, couplings and nipple** used for proper connection to the pump, suction and delivery.
- (c) **Pressure gauge:** It is necessary to know whether the sprinkler system is working with desired pressure to ensure application uniformity.
- (d) **Bend, tees, reducers, elbows, hydrants, butterfly valve and plugs.**
- (e) **Fertilizer applicator:** Soluble chemical fertilizers can be injected into the sprinkler system and applied to the crop. The equipment for fertiliser application is relatively cheap and simple and can be fabricated locally. The fertilizer applicator consists of a sealed fertilizer tank with necessary tubings and connections. A venturi injector can be arranged in the main line, which creates the differential pressure suction and allows the fertilizer solution to flow in the main water line.



**QRC HDPE sprinkler with metal latches**

**QRC HDPE sprinkler with plastic latches**

**QRC HDPE sprinkler base**



**QRC HDPE pump connector**



**QRC HDPE bend**



**QRC HDPE tee**



**QRC HDPE end plug**

**Fig 2.5 Different sprinkler pipes and fittings**

### General rules for sprinkler system design

- Main should be laid up and down hill
- Lateral should be laid across the slope or nearly on the contour
- For multiple lateral operation, lateral pipe sizes should not be more than two diameter
- Water supply source should be nearest to the center of the area
- Layout should facilitate and minimize lateral movement during the season
- Booster pump should be considered where small portion of field would require high pressure at the pump
- Layout should be modified to apply different rates and amounts of water where soils are greatly different in the design area.

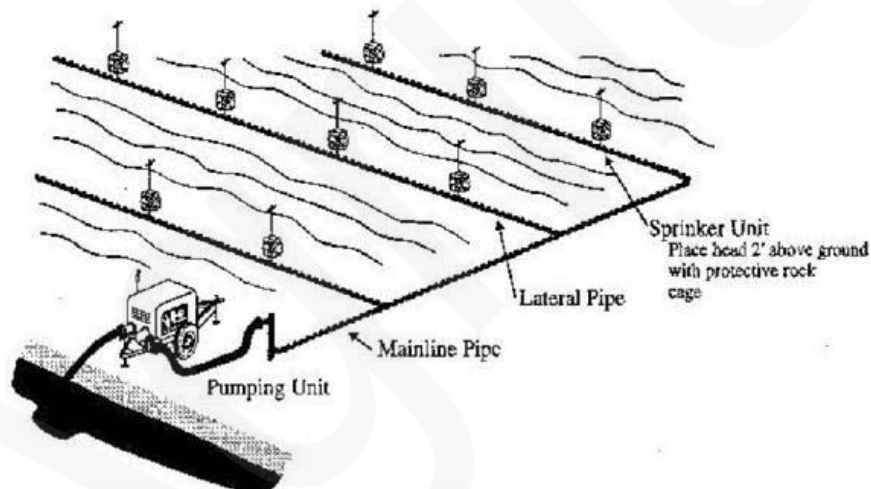

**Fig.6 Layout of sprinkler irrigation system**

### Selecting the most appropriate sprinkler systems

While selecting a sprinkler system, the most important physical parameters to be considered are:

1. The crop or crops to be cultivated.
2. The shape and size (acres) of the field.
3. The topography of the field.
4. The amount of time and labor required to operate the system.

### **Selecting sprinkler system capacity**

A sprinkler system must be designed to apply water uniformly without runoff or erosion. The application rate of the sprinkler system must be matched to the infiltration rate of the most restrictive soil in the field. If the application rate exceeds the soil intake rate, the water will runoff the field or relocate within the field resulting in over and under watered areas.

The sprinkler system capacity is the flow rate needed to adequately irrigate an area and is expressed in liters per minute per acre. The system capacity depends upon on the: Peak crop water requirements during the growing season; effective crop rooting depth; texture and infiltration rate of the soil; the available water holding capacity of the soil; pumping capacity of the well or wells (if wells are the water source).

### **Constraints in application of sprinkler irrigation**

- (i) Uneven water distribution due to high winds
- (ii) Evaporation loss when operating under high temperatures
- (iii) Highly impermeable soils are not suitable
- (iv) Initial cost is high
- (v) Proper design
- (vi) Lack of Package of practices
- (vii) Lack of awareness
- (viii) Lack of social concern to save natural resources
- (ix) High water pressure required in sprinkler ( $>2.5\text{kg/cm}^2$ )
- (x) Difficulty in irrigation during wind in sprinkler

### **Operation and Maintenance of Sprinkler Systems**

Proper design of a sprinkler system does not in itself ensure success. It should be ensured that the prime mover and the pump are in alignment, particularly in the case of tractor-driven pumps. For these the drive shaft as well as the pump shaft should lie at nearly the same height to prevent too great an angle on the universal shaft.

While laying the main and lateral pipes, always begin laying at the pump. This necessarily gives the correct connection of all quick coupling pipes. While joining couplings, it is ensured that both the couplings and the rubber seal rings are clean.

In starting the sprinkler system, the motor or engine is started with the valves closed. The pump must attain the pressure stated on type-plate or otherwise there is a fault in the suction line. After the pump reaches the regulation pressure, the delivery valve is opened slowly. Similarly, the delivery valve is closed after stopping the power unit.

The pipes and sprinkler-lines are shifted as required after stopping. Dismantling of the installation takes place in the reverse order to the assembly described above.

### **Maintenance**

General principles regarding the maintenance of the pipes and fittings and sprinkler heads are given below:

#### **1. Pipes and fittings**

The pipes and fittings require virtually no maintenance but attention must be given to the following procedures:

- (a) Occasionally clean any dirt or sand out of the groove in the coupler in which the rubber sealing ring fits. Any accumulation of dirt or sand will affect the performance of the rubber sealing ring.
- (b) Keep all nuts and bolts tight.
- (c) Do not lay pipes on new damp concrete or on piles of fertilizer. Do not lay fertilizer sacks on the pipe.

#### **2. Sprinkler heads**

The sprinkler heads should be given the following attention:

- (a) When moving the sprinkler lines, make sure that the sprinklers are not damaged or pushed into the soil.
- (b) Do not apply oil, grease or any lubricant to the sprinklers. They are water lubricated and using oil, grease or any other lubricant may stop them from working.
- (c) Sprinklers usually have a sealed bearing and at the bottom of the bearing there are washers. Usually it is the washers that wear and not the more expensive metal parts.

Check the washers for wear once a season or every six months which is especially important where water is sandy. Replace the washers if worn.

(d) After several season's operation the swing arm spring may need tightening. This is done by pulling out the spring end at the top and rebending it. This will increase the spring tension.

In general, check all equipment at the end of the season and make any repairs and adjustments and order the spare parts immediately so that the equipment is in perfect condition to start in the next season.

### **Storage**

The following points are to be observed while storing the sprinkler equipment during the off season:

- (a) Remove the sprinklers and store in a cool, dry place.
- (b) Remove the rubber sealing rings from the couplers and fittings and store them in a cool, dark place.
- (c) The pipes can be stored outdoors in which case they should be placed in racks with one end higher than the other. Do not store pipes along with fertilizer.
- (d) Disconnect the suction and delivery pipe-work from the pump and pour in a small quantity of medium grade oil. Rotate the pump for a few minutes. Blank the suction and delivery branches. This will prevent the pump from rusting. Grease the shaft.
- (e) Protect the electric motor from the ingress of dust, dampness and rodents.

### **Trouble Shooting**

The following are the general guidelines to identify and remove the common troubles in the sprinkler systems:

#### **1. Pump does not prime or develop pressure**

- (a) Check that the suction lift is within the limits. If not, get the pump closer to the water.
- (b) Check the suction pipeline and all connections for air leaks. All connections and flanges should be air tight.

- (c) Check that the strainer on the foot valve is not blocked.
- (d) Check that the flap in the foot valve is free to open fully.
- (e) Check the pump gland (s) for air leaks. If air leaks are suspected tighten the gland (s) gently. If necessary repack the gland (s) using a thick grease to seal the gland satisfactorily.
- (f) Check that the gate valve on the delivery pipe is fully closed during priming and opens fully when the pump is running.

## **2. Sprinklers do not turn**

- (a) Check pressure.
- (b) Check that the nozzle is not blocked. Preferably unscrew the nozzle or use a small soft piece of wood to clear the blockage. Do not use a piece of wire or metal as this may damage the nozzle.
- (c) Check the condition of washers at the bottom of the bearing and replace them if worn or damaged.
- (d) Check that the swing arm moves freely and that the spoon which moves into the water stream is not bent by comparing it with a sprinkler which is operating correctly.
- (e) Adjust the swing arm spring tension~ Usually it should not be necessary to pull up the spring by more than about 6 mm.

## **3. Leakage from coupler or fittings**

The sealing rings in the couplers and fittings are usually designed to drain the water from the pipes when the pressure is turned off. This ensures that the pipes are automatically emptied and ready to be moved. With full pressure in the system the couplers and fittings will be effectively leak-free. If, however, there is a leakage, check the following:

- (a) There is no accumulation of dirt or sand in the groove in the coupler in which the sealing ring fits. Clean out any dirt or sand and refit the sealing ring.
- (b) The end of the pipe going inside the coupler is smooth, clean and not distorted.
- (c) In the case of fittings such as bends, tees and reducers ensure that the fitting has been properly connected into the coupler.

**Unit Cost of Sprinkler Systems**

Different components required for a sprinkler irrigation system to irrigate 1 ha to 4 ha area and their cost has been estimated and given in Table .3

**Table .3 Unit Cost of Sprinkler Systems**

Sprinkler System Components	1.0 ha (50mm dia)		2.0 ha (63mmdia)		3.0 ha(75mm dia)		4.0 ha (75 mm dia)	
	Quantity	Amount (Rs.)	Quantity	Amount (Rs.)	Quantity	Amount (Rs.)	Quantity	Amount (Rs.)
	(No.)		(No.)		(No.)		(No.)	
HDPE Pipes with quick action coupler (2.5 kg/cm <sup>2</sup> ) of 6m long	25	7770.00	30	10448.70	37	13378.09	45	16270.65
Sprinkler coupler with foot baton assembly	5	921.60	7	1411.20	11	2382.30	14	3032.00
Sprinkler nozzles (1.7 to 2.8 kg/cm <sup>2</sup> )	5	1188.00	7	1662.20	11	2613.60	14	3326.40
Riser pipe 20mm diameter x 75cm long	5	264.00	7	369.60	11	580.80	14	739.20
Connecting nipple	1	115.20	1	129.00	1	167.00	1	167.00
Bend with coupler 90 <sup>0</sup>	1	108.00	1	126.00	1	168.00	1	168.00
Tee with coupler	1	138.00	1	152.40	1	180.00	1	180.00
End plug	2	96.00	2	108.00	2	132.00	2	132.00
Basic system cost per hectare (Rs.)		10600.80		14407.10		19601.79		24015.25

## Lec 17

### PLASTIC MULCHING FOR CROP PRODUCTION

#### Introduction

Mulching is the process or practice of covering the soil/ground to make more favourable conditions for plant growth, development and efficient crop production. Mulch technical term means 'covering of soil'. While natural mulches such as leaf, straw, dead leaves and compost have been used for centuries, during the last 60 years the advent of synthetic materials has altered the methods and benefits of mulching. The research as well as field data available on effect of synthetic mulches make a vast volume of useful literature. When compared to other mulches plastic mulches are completely impermeable to water; it therefore prevents direct evaporation of moisture from the soil and thus limits the water losses and soil erosion over the surface. In this manner it plays a positive role in water conservation. The suppression of evaporation also has a supplementary effect; it prevents the rise of water containing salt, which is important in countries with high salt content water resources.

#### Advantages of plastic mulching

1. It is completely impermeable to water.
2. It prevents the direct evaporation of moisture from the soil and thus limits the water losses and conserves moisture.
3. By evaporation suppression, it prevents the rise of water containing salts.
4. Mulch can facilitate fertilizer placement and reduce the loss of plant nutrient through leaching.
5. Mulches can also provide a barrier to soil pathogens
6. Opaque mulches prevent germination of annual weeds from receiving light
7. Reflective mulches will repel certain insects
8. Mulches maintain a warm temperature even during nighttime which enables seeds to germinate quickly and for young plants to rapidly establish a strong root growth system.
9. Synthetic mulches play a major role in soil solarisation process.
10. Mulches develop a microclimatic underside of the sheet, which is higher in carbon-di-oxide due to the higher level of microbial activity.

### Lec 17

11. Under mulch, the soil structure is maintained during cropping period
12. Early germination almost 2-3 days.
13. Better nodulation in crops like Groundnut.
14. Less nematodes population.
15. Water erosion is completely averted since soil is completely covered from bearing action of rain drops.
16. When compared to organic mulches, it serves for a longer period.

#### Moisture conservation

- Plastic film with its moisture barrier properties does not allow the soil moisture to escape. Water that evaporates from the soil surface under mulch film, condenses on the lower surface of the film and falls back as droplets.
- Thus moisture is preserved for several days and increases the period between two irrigations.
- The irrigation water or rainfall either moves into the soil thru holes on the mulch around the plant area or through the un-mulched area.

#### Weed control

- Black plastic film does not allow the sunlight to pass through on to the soil
- Photosynthesis does not take place in the absence of sunlight below black film hence, it arrests weed growth



## Lec 17

### Limitations

- They are costly to use in commercial production when compared to organic mulches.
- Probability of ‘burning’ or ‘scorching’ of the young plants due to high temperature of black film.
- Difficulty in application of top dressed fertilizer
- Reptile movement and rodent activities are experienced in some places.
- More runoff
- Environmental pollution
- Difficult in machinery movement
- Can not be used for more than one season using thin mulches
- Weed penetration with thin films
- Toxic to livestock

### Areas of application

Mulching is mainly employed for

- a. Moisture conservation in rainfed areas
- b. Reduction of irrigation frequency and water saving in irrigated areas
- c. Soil temperature moderation in greenhouse cultivation
- d. Soil solarisation for control of soil borne diseases
- e. Reduce the rain impact, prevent soil erosion and maintain soil structure
- f. In places where high value crops only to be cultivated

### Types of mulch film

A wide range of plastic films based on different types of polymers have all been evaluated for mulching at various periods in the 1960s. LDPE, HDPE and flexible PVC have all been used and although there were some technical performance differences between them, they were of minor nature. Owing to its greater permeability to long wave radiation which can increase the temperature around plants during the night times, polyethylene is preferred. Today the vast majority of plastic mulch is based on LLDPE because it is more economic in use.

## Lec 17

### Basic properties of mulch film

- a. Air proof so as not to permit any moisture vapour to escape.
- b. Thermal proof for preservation of temperature and prevention of evaporation
- c. Durable at least for one crop season

### Importance of parameters of the plastic film

#### a) Thickness

Normally the thickness of the film does not affect the mulching effect except when it is used for solarisation. But some of the recent references do indicate the impact of film thickness on crop yield. Since it is sold by weight it is advantageous to use as thin a film as possible but at the same time due consideration should be given for the longevity of the film. The early mulch film used were of 60-75 micron (240-300 gauge) thickness, and today it is possible to have 15 micron thick film due to advent of film extrusion technology. These films are mechanically weak, as shown by their easy tearing when pulled tension.

#### b) Width

This depends upon the inter row spacing. Normally a one to one and half meter width film can be easily adopted to different conditions.

#### c) Perforations

The perforations may be advantageous under some situations and disadvantageous for some other situation. The capillary movement of water and fertilizer distribution will be better and more uniform under unperforated condition. But for prevention of water stagnation around the plants, perforation is better. But it has got the disadvantages of encouraging weed growth.

#### d) Mulch colour

The colour of the mulch affects

- i. Soil temperature
- ii. Temperature of air around the plants
- iii. Soil salinity
  - a. Due to lesser quantity of water used
  - b. Due to reduction in evaporation and prevention of upward movement of water.

## Water Management including Micro Irrigation

### Lec 17

- Transparant film - Deposits more salt on soil surface
- Black film - Restricts water movement and upward movement of salt is reduced.
- iv. Weed flora - Black film
- v. Insect control - Opaque white film acts as golden colour and attracts insects



## Lec 17

### Selection of mulch

The selection of mulches depends upon the ecological situations and primary and secondary aspects of mulching

Rainy season	- Perforated mulch
Orchard and plantation	- Thicker mulch
Soil solarisation	- Thin transparent film
Weed control through solarisation	- Transparent film
Weed control in cropped land	- Black film
Sandy soil	- Black film
Saline water use	- Black film
Summer cropped land	- White film
Insect repellent	- Silver colour film
Early germination	- Thinner film

### Methods of mulching

- Orchard/Fruit/Established trees
- Mulching area should preferably be equivalent to the canopy of the plant.
- Required size of mulch film is cut from the main roll.
- Clean the required area by removing the stones, pebbles, weeds etc.
- Till the soil well and apply a little quantity of water before mulching
- Small trench could be made around the periphery of the mulching area to facilitate anchoring of the mulch film.
- Cover the film to the entire area around the tree and the end should be buried in the ground.
- Semi circular holes could be made at four corners of the film in order to facilitate water movement.
- The position of the slit/opening should be parallel to the wind direction

## Lec 17

- Cover the corners of the film with 4-6 inches of soil on all sides to keep the film in position.
- In hard soil, make a trench of 1'x1'x2' depth on four corners of the mulching area and fill it up with gravel or stones, cover the trenches with the mulch film and allow the water to pass through the mulch to the trenches via semi circular holes on the film

### Mulch Laying Techniques

- i. Mulch should be laid on a non-windy condition
- ii. The mulch material should be held tight without any crease and laid on the bed
- iii. The borders (10 cm) should be anchored inside the soil in about 7-10 cm deep in small furrows at an angle of 45°.

### Pre planting mulch:

The mulch material should be punctured at the required distances as per crop spacing and laid on the bed. The seeds/seedlings should be sown/transplanted in the holes.

### Mulching techniques for Vegetables /close space crop

- Very thin film is used for short duration crops like vegetables.
- Required length of film for one row of crop is taken and folded in 'thaan' form at every one metre along the length of the film.
- Round holes are made at the center of the film using a punch or a bigger diameter pipe and a hammer or a heated pipe end could be used.
- One end of the mulch film (along width) is anchored in the soil and the film is unrolled along the length of the row of planting.
- Till the soil well and apply the required quantity of FYM and fertilizer before mulching.
- Mulch film is then inserted (4-6") into the soil on all sides to keep it intact
- Seeds are sown directly through the holes made on the mulch film.
- In case of transplanted crops, the seedlings could be planted directly into the hole.
- For mulching established seedlings, the process of punching the hole is the same. One end of the film along the width is burried in the soil and the mulch film is then unrolled over the saplings. During the process of unrolling, the saplings are

AgriFair

## Lec 17

held in the hand and inserted into the holes on the mulch film from the bottom side, so that it could spread on the topside.

### Precautions for Mulch Laying

- Do not stretch the film very tightly. It should be loose enough to overcome the expansion and shrinkage conditions caused by temperature and the impacts of cultural operation.
- The slackness for black film should be more as the expansion, shrinkage phenomenon is maximum in this color.
- The film should not be laid on the hottest time of the day, when the film will be in expanded condition.

### Removal of mulch

In case the mulch film needs to be used for more than one season (thicker film) the plant is cut at its base near the film and the film is removed and used.

By compounding appropriate additives into the plastics it is possible to produce a film, which, after exposure to light (solar radiation) will start to breakup at a pre determined time and eventually disintegrated into very small friable fragments. The time period can be 60, 90, 120 or 150 days and for maize a 60-day photodegradable mulch is used. However there are still some further problems to resolve. It has been observed that the edges of the mulch, which are buried to secure the mulch to the soil, remain intact and become a litter problem when brought to the surface during the post-harvest ploughing. Currently much development effort is being made to find a satisfactory solution to this problem.

In direct contrast in developing countries which have agricultural labour available a different approach can be made. For example in the people Republic of China trials have been made using a plastic mulch of 15 micron thickness on a sugarcane crop. After the cuttings have been planted through the mulch they are left to grow for a period of one month. Then the mulch is removed by hand and wound up so that it can be utilized for a second season. A yield increase of 26% was obtained.

These two examples not only demonstrated the diversity of mechanisms available for resolving the problems of mulch removed, but also illustrate the different technique, which have been developed in different countries. It also indicates the necessity for each country to adapt and develop mulching technique to meet its own specific requirements

AgriFair

### Lec 17

of climate, resources and economics. To undertake such technology development there is a specific requirement that both plastics and agricultural development facilities are available.

#### Irrigation practices under mulching

- In drip irrigation the lateral pipelines are laid under the mulch film
- In case inter-cultivation need to be carried out, it is better to keep the laterals and drippers on top of the mulch film and regulate the flow of water through a small pipe or through the holes made on the mulch film



- In flooding the irrigation water passes through the semi circular holes on the mulch sheet.

#### Cost economics of mulching

The cost economic of mulching is an important aspect. In a leveled field if mulching is to be done, then the film area required will be almost equal to that of field itself. In fields with ridges and furrows mulching material required will be sizably more than the field area. However mulching is carried out in strips covering 50-60% of field area. In the present era of minimizing rainfall conserving moisture with mulching transgresses the plan of economic analysis in the sense that the real cost analysis would be even meaningless in the case of a precious commodity like water. A typical calculation has been given for working out cost economics of mulching in Bhendi crop.

## Lec 17

### Assumptions made in cost estimation

- Power and source of water are available.
- Price of synthetic film of black LLDPE is taken as Rs. 120 per Kg.
- PVC film is assumed to last for 2 seasons only. However in practice, black PVC film may well last longer than two seasons, if handled properly, in that case savings could be correspondingly larger.

### Cost Economics of mulching

Sl. No.	Particulars	Black LLDPE film	Control
1	Cost of cultivation (Rs. / ha)	16000	21000
2	Cost of mulch film per season	16600	--
3	Total seasonal cost (2+1)	32600	21000
4	Yield of produce (kg/ha)	11660	7770
5	Market price (Rs./kg)	6.00	6.00
6	Revenue (Rs./ha)	69960	46620
7	Total expenditure	32600	*21000
8	Net income	37360	25620
9	Difference in net seasonal income	11740	25620
10	Benefit cost ratio	1.45: 1	

\* 60% area covered with film,

50 micron film of 1 kg cover 22 sq. m

### Case studies

#### Effect of mulching on groundnut

An experiment on mulching with plastic films was conducted for groundnut Aliyarnagar Research Station. The film was LLDPE black and the thickness were 15 micron (T1), 20 micron (T2), 25 micron (T3), coir pith at the rate of 20 t/ha (T4) and fifth plot was control (T5). Each plot was 2m x 1m and experiments were replicated four times. For sampling purpose, 5 plants in each of the experimental plots were considered for rot length on 60<sup>th</sup> day. The crop was harvested on 110<sup>th</sup> day since sowing. Parameters like soil moisture, soil temperature, germination; weed, root and yield were observed.

## Lec 17

**Plastic mulching in groundnut**

Treatment	Available moisture at harvest (%)	Wet weed wt. (g)/plot at 45 <sup>th</sup> day	No. of pods/plant	Pod yield (kg/ha)
T <sub>1</sub> – 15 micron LLDPE (black)	7.69	150	9.00	1337
T <sub>2</sub> – 20 micron LLDPE (black)	7.62	156	7.75	1118
T <sub>3</sub> – 25	7.05	179	7.50	1275
T <sub>4</sub> – Coir pith 20 t/ha	6.50	257	6.75	1012
T <sub>5</sub> Control – no mulch	5.90	370	6.75	850

Mulching with 15 micron LLDPE film was found to give higher pod yield due to better moisture conservation, reduced weed growth, when compared to coirpith mulch and control. From the results it was also seen that the thickness of film did not matter much in conserving moisture.

**Effect of mulching on cotton crop**

Experiments were conducted at TNAU, by PDC, CAE for dry land cotton, covering 50% of land area by 25 micron LLDPE black polyethylene film. The replicated trial was repeated for 3 seasons from 1992-93 for LRA 5166 cotton variety. For comparative study purpose coir pith at a rate of 12.5 t/ha and organic mulch of 12.5 t/ha were also taken. Plot size was 5 m x 4 m.

### Lec 17

#### Effect of mean yield of cotton over 3 years

Treatments	Mean kapas yield (kg/ha)	Wet weed wt./plot (gm) at 45th day
Black LLDPE (20 micron)	673	303
Coir pith	565	575
Organic mulch	509	510
No mulch	436	1121

#### Effect of mulch on root length and plant height in castor and redgram

To study the effect of mulching on plant height and root length under dryland conditions plants like redgram and castor crop were selected and trials were conducted at TNAU campus. The results are as shown below:

#### Effect of mulch on plant height and root length

Treatment	Red gram (SAI)			Castor (CO 1)		
	Plant height (cm)	Root length (cm)	Root No.	Plant height (cm)	Root length (cm)	Root No.
30 mic. LLDPE black	45.0	25.3	5	50.1	38.3	8
40 mic. LLDPE black	41.6	20.7	3	48.7	35.8	5
50 mic. LLDPE black	41.9	23.0	3	48.0	34.3	5
No mulch	22.1	20.9	4	30.1	28.6	6

#### Effect of mulching on vegetable crops

From the year 1986 onwards, Coimbatore PDC is continuously conducting experiments on mulching for principal vegetable crops like Bhendi, Tomato and Chilli. Replicated trials were conducted with three irrigation levels and two type of mulches as follows.

I<sub>1</sub> – Irrigation at 0.41 IW/CPE

M<sub>0</sub> – Control – no mulch

I<sub>2</sub> – Irrigation at 0.61 IW/CPE

M<sub>1</sub> – Control – no mulch

I<sub>3</sub> – Irrigation at 0.61 IW/CPE

M<sub>2</sub> – Control – no mulch

The plot size was 5.5 m x 2.5 m/each

### Lec 17

Each experiment was repeated thrice in different season for the same variety of crop for confirming the results. The mean values of yields of each crop are tabulated below.

#### 1. Bhendi

##### Effect of mulching on Bhendi yield (4 year average) in kg/ha

Treatment	M <sub>0</sub>	M <sub>1</sub>	M <sub>2</sub>	Mean
I <sub>1</sub>	6593	8249	11292	8698
I <sub>2</sub>	8145	9156	12173	9825
I <sub>3</sub>	8571	8686	11555	9604
Mean	77770	8697	11660	

#### 2. Tomato

##### Effect of mulching on tomato yield

Mean yield data over three years

Treatment	M <sub>0</sub>	M <sub>1</sub>	M <sub>2</sub>	Mean
I <sub>1</sub>	8322	10260	11767	10116
I <sub>2</sub>	9527	11415	13012	11318
I <sub>3</sub>	11916	12326	13427	12556
Mean	9922	11334	12735	
		(14.2)*	(28.4)*	

\*Percentage of yield increase over unmulched control / plot

#### 3. Chilli

##### Effect of mulching on Chilli yield

Mean yield data over three years

Treatment	M <sub>0</sub>	M <sub>1</sub>	M <sub>2</sub>	Mean
I <sub>1</sub>	3972	4353	4916	4414
I <sub>2</sub>	4732	5115	5475	5107
I <sub>3</sub>	4940	5359	5872	5390
Mean	4548	4942	5421	

## Lec 17

### Effect of mulching on maize crop

Experiments conducted in TNAU main campus showed that evaporation loss from the maize crop field can be arrested by covering the soil either with plastic film of 20 micron (80 gauge) of black sheet or with organic farm waste like cumbu straw. Due to this water economizing to the level of 12-20% was achieved. Hence it is a viable technology under moisture stress condition.

### Effect of mulching on maize yield and WUE

Treatment	Seasonal total water (mm)	Yield in kg/ha	WUE (kg/ha mm)
1. Control	463	5562	11.90
2. Plastic mulch with 20 micron	373	5650	15.10
3. Cumbu straw	401	5594	13.90
4. Coir pith	403	5466	13.86

### Conclusions on basis of experiments conducted so far

1. Flexible PVC film is suitable for mulching. PVC film shows the expected over all advantages of mulch irrigation such as conservation of moisture and control of weed growth.
2. Savings in water appear to be the main advantage and such savings are found to vary from 20% to as high as 75%. The savings in water are more pronounced in arid areas. These experiments clearly established that such savings could be of critical importance in arid areas. Areas having elaborate irrigation do not appear to show considerable advantage. Mulching, therefore, would appear and promising for arid lands.
3. Yields of crops may not necessarily be substantially increased directly by usage of mulching, but more land can be cultivated with the available amount of water and thus overall cultivation of crops can be increased. However, it is significant to not that in both experiments conducted in arid areas increased yields were reported.

### Lec 17

4. 150-200 gauge PVC film based on normal compositions would withstand weathering for 2 seasons. However, the life of film could be increased by covering the film with the soil and thus preventing direct exposure of the film to sunlight. PVC film based on special compositions would certainly have better weather resistance and would last for several seasons. Black as well as completely opaque, white film would be better than natural semi-transparent film in respect of weather resistance. Black film would appear to be better for colder climates while opaque white film would show some advantages for warm climates.
5. Black PVC film shows better control on weed growth than completely opaque white and natural translucent film.

### Conclusion

Plasticulture is crucial to Indian agriculture in view of the changing technological scenario for boosting crop yields and productivity. Introduction of linear low density polyethylene (LLDPE) as a mulch film has brought a revolution in agricultural water management. It is actually a boon to dryland farmers. This is one of the fastest growing plasticultural applications in the world. The cost of LLDPE film is also lesser than one third of LDPE mulch film. Moreover for mulch activity lower thickness (15 to 20 microns) are highly suitable. However due to ever increasing cost of raw materials the films are costlier now. Hence Government should take all possible measures to produce the film in a mass scale and make it available to the farmers at a reasonable price. Subsidy may also be given through banks to encourage the farmer to adoption soil mulching. Low cost machines may be developed for spreading and rolling down the film in the field. PFDC's may be geared up for large scale demonstration in farmer's field to give a wide publicity.

## Lec 17

## Studies on mulching at various centres of PFDC's all over India

Sl. No.	Crop	Location of PFDC	Mulch material	Increase in yield (%)	Additional income (Rs./ha)
1.	Chilli	Navasari (Gujarat)	Black plastic (50 micron)	60.1	10140.00
2.	Brinjal	Navasari (Gujarat)	Black plastic (50 micron)	27.1	7400.00
3.	Sugarcane	Navasari (Gujarat)	Black plastic (50 micron)	50.2	25000.00
4.	Chilli	Navasari (Gujarat)	Green plastic (50 micron)	59.0	22190.00
5.	Cauliflower	Hisar	Black plastic (50 micron)	31.9	6751.00
6.	Potato	Pantnagar (UP)	Black plastic (50 micron)	35.5	8700.00
7.	Cauliflower	Pantnagar (UP)	Black plastic (50 micron)	71.0	16120.00
8.	Tomato	Pantnagar (UP)	Plastic film (25 micron)	46.5	11250.00
9.	Okra	Pantnagar (UP)	Plastic film (25 micron)	47.85	9250.00
10.	Tomato	Pantnagar (UP)	Plastic film (25 micron)	79.2	22764.00
11.	Tomato	Kharagpur (WB)	Plastic film (25 micron)	65.4	43210.00
12.	Okra	Kharagpur (WB)	Plastic film (25 micron)	55.1	19625.00
13.	Guava	Delhi	Plastic film (100 micron)	26.0	--
14.	Lemon	Delhi	Plastic film (100 micron)	21.6	--
15.	Kinnow	Delhi	Plastic film (100 micron)	46.8	--
16.	Pomogranate	Delhi	Plastic film (100 micron)	33.3	
17.	Brinjal	Coimbatore	Plastic film (25 micron)	33.3	12062.00
18.	Bhendi	Coimbatore	Plastic film (25 micron)	46.7	9770.00
19.	Bhendi	Coimbatore	Plastic film (25 micron)	54.0	6400.00
20.	Chilli	Coimbatore	Plastic film (25 micron)	18.6	6800.00
21.	Groundnut	Coimbatore	Plastic film (15 micron)	20.5	7300.00
22.	Banana	Travacore (Kerala)	Plastic film (50 micron)	12.6	13906.00
23.	Arecanut	Travacore (Kerala)	Plastic film (50 micron)	28.4	--
24.	Bhendi	Travacore (Kerala)	Plastic film (50 micron)	25.0	18885.00
25.	Maize	Rajendranagar (AP)	Plastic film (25 micron)	44.6	9800.00
26.	Brinjal	Rajendranagar (AP)	Plastic film (25 micron)	10.0	15100.00
27.	Bhendi	Rajendranagar (AP)	Plastic film (25 micron)	67.0	18300.00
28.	Tomato	Rajendranagar (AP)	Plastic film (25 micron)	65.3	13800.00
29.	Plum	Solan (HP)	Plastic film (50 micron)	9.2	12000.00
30.	Tomato	Solan (HP)	Plastic film (50 micron)	85.6	18250.00
31.	Pea	Solan (HP)	Plastic film (50 micron)	66.6	25960.00
32.	Apricot	Solan (HP)	Plastic film (50 micron)	33.3	18320.00
33.	Peach	Solan (HP)		31.2	13890.00

## LEC. 18 & 19. METHODS OF IRRIGATION - SUITABILITY, ADVANTAGES AND LIMITATIONS

**Water application methods are grouped as:**

1. Flooding
2. Applying it beneath the soil surface
3. Spraying it under pressure
4. Applying in drops

### **Irrigation methods**

- I. Surface
- II. Sub-surface
- III. Pressurized irrigation

**Surface** is grouped as Border, Check basin and Furrow irrigations. Border is again classified in to two as straight and contour. Check basins may be of rectangular, contour or ring, whereas furrow irrigation is classified as deep furrow and corrugated furrows. These may be again straight or contour according to direction and leveled and graded as per their elevation

### **I. Surface irrigation**

#### **1. Border irrigation**

- The land is divided into number of long parallel strips called borders.
- These borders are separated by low ridges.
- The border strip has a uniform gentle slope in the direction of irrigation.
- Each strip is irrigated independently by turning the water in the upper end.
- The water spreads and flows down the strip in a sheet confined by the border ridges.

**Suitability :** To soils having moderately low to moderately high infiltration rates. It is not used in coarse sandy soils that have very high infiltration rates and also in heavy soils having very low infiltration rate. Suitable to irrigate all close growing crops like wheat, barley, fodder crops and legumes and not suitable for rice.

### Advantages

1. Border ridges can be constructed with simple farm implements like bullock drawn “A” frame ridger or bund former.
2. Labour requirement in irrigation is reduced as compared to conventional check basin method.
3. Uniform distribution of water and high water application efficiencies are possible.
4. Large irrigation streams can be efficiently used.
5. Adequate surface drainage is provided if outlets are available.

Width of border strip: It varies from 3-15 m

Border length

Slope	Soil	Length
0.25 - 0.60%	Sandy and sandy loam	60-120 m
0.20 - 0.40%	Medium loam soil	100-180 m
0.05 – 0.20%	Clay loam and clay soil	150-300 m

### 2. Check basin irrigation

- It is the most common method.
- Here the field is divided into smaller unit areas so that each has a nearly level surface.
- Bunds or ridges are constructed around the area forming basins within which the irrigation water can be controlled.
- The water applied to a desired depth can be retained until it infiltrates into the soil.
- The size of the basin varies from 10m<sup>2</sup> to 25 m<sup>2</sup> depending upon soil type , topography, stream size and crop.

### Adaptability

- ✓ Small gentle and uniform land slopes
- ✓ Soils having moderate to slow infiltration rates.
- ✓ Adapted to grain and fodder crops in heavy soils.
- ✓ Suitable to permeable soils.

## Water Management including Micro Irrigation

### Advantages

1. Check basins are useful when leaching is required to remove salts from the soil profile.
2. Rainfall can be conserved and soil erosion is reduced by retaining large part of rain
3. High water application and distribution efficiency.

### Limitations

1. The ridges interfere with the movement of implements.
2. More area occupied by ridges and field channels.
3. The method impedes surface drainage
4. Precise land grading and shaping are required
- 5. Labour requirement is higher.**
6. Not suitable for crops which are sensitive to wet soil conditions around the stem.

### Furrow irrigation

- ⇒ Used in the irrigation of row crops.
- ⇒ The furrows are formed between crop rows.
- ⇒ The dimension of furrows depend on the crop grown, equipment used and soil type.
- ⇒ Water is applied by small running streams in furrows between the crop rows.
- ⇒ Water infiltrates into soil and spreads laterally to wet the area between the furrows.
- ⇒ In heavy soils furrows can be used to dispose the excess water.

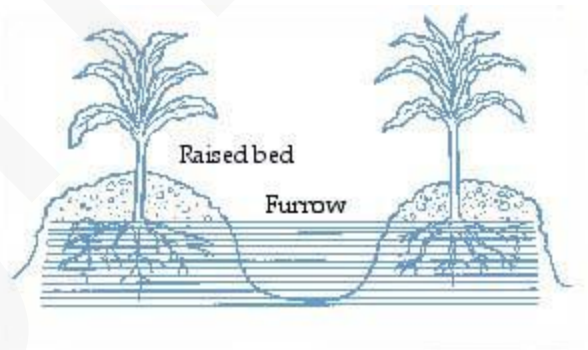

### Adaptability

1. Wide spaced row crops including vegetables.
2. Suitable for maize, sorghum, sugarcane, cotton, tobacco, groundnut, potatoes
3. Suitable to most soils except sand.

Agrifair

### Advantages

1. Water in furrows contacts only one half to one fifth of the land surface.
2. Labour requirement for land preparation and irrigation is reduced.
3. Compared to check basins there is less wastage of land in field ditches.



### Types of furrow irrigation

Based on alignment of furrows

- : 1. Straight furrows
- 2. Contour furrows

Based on size and spacing : 1. Deep furrows 2. Corrugations

### Based on irrigation:

- All furrow irrigation:** Water is applied evenly in all the furrows and are called furrow system or uniform furrow system.
- Alternate furrow irrigation:** It is not an irrigation layout but a technique for water saving. Water is applied in alternate furrows for eg. During first irrigation if the even

numbers of furrows are irrigated, during next irrigation, the odd number of furrows will be irrigated.

- C. **Skip furrow irrigation:** They are normally adopted during the period of water scarcity and to accommodate intercrops. In the skip furrow irrigation, a set of furrows are completely skipped out from irrigation permanently. The skipped furrow will be utilized for



raising intercrop. The system ensures water saving of 30-35 per cent. By this method, the available water is economically used without much field reduction.

- D. **Surge irrigation:** Surge irrigation is the application of water in to the furrows intermittently in a series of relatively short ON and OFF times of irrigation cycle. It has been found that intermittent application of water reduces the infiltration tare over surges thereby the water front advances quickly. Hence, reduced net irrigation water requirement. This also results in more uniform soil moisture distribution and storage in the crop root zone compared to continuous flow. The irrigation efficiency is in between 85 and 90%.

## II. Sub-surface irrigation

- ◆ In subsurface irrigation, water is applied beneath the ground by creating and maintaining an artificial water table at some depth, usually 30-75 cm below the ground surface.
- ◆ Moisture moves upwards towards the land surface through capillary action
- ◆ Water is applied through underground field trenches laid 15-30 m apart.

## Water Management including Micro Irrigation

- ◆ Open ditches are preferred because they are relatively cheaper and suitable to all types of soil.
- ◆ The irrigation water should be of good quality to prevent soil salinity.

### Advantages

1. Minimum water requirement for raising crops
2. Minimum evaporation and deep percolation losses
3. No wastage of land
7. No interference to movement of farm machinery
8. Cultivation operations can be carried out without concern for the irrigation period.

### Disadvantages

1. Requires a special combination of natural conditions.
2. There is danger of water logging
3. Possibility of choking of the pipes lay underground.
4. High cost.

### DRIP IRRIGATION SYSTEM

- Drip or trickle irrigation is one of the latest methods of irrigation.
- It is suitable for water scarcity and salt affected soils.
- Water is applied in the root zone of the crop

Standard water quality test needed for design and operation of drip irrigation system.

*(Major inorganic salts, hardeners, suspended solids, total dissolved solids, biological oxygen demand, chemical oxygen demand, organic, and organic matter, micro-organisms, iron, dissolved oxygen, H<sub>2</sub>S, iron bacteria, sulphur reducing bacteria etc have to be tested)*

### Components

- ◆ A drip irrigation system consists of a pump or overhead tank, main line, sub-mains, laterals and emitters.

## Water Management including Micro Irrigation

- ◆ The mainline delivers water to the sub-mains and the sub-mains into the laterals.
- ◆ The emitters which are attached to the laterals distribute water for irrigation.
- ◆ The mains, sub-mains and laterals are usually made of black PVC (poly vinyl chloride) tubing. The emitters are also made of PVC material
- ◆ The other components include regulator, filters, valves, water meter, fertilizer application components, etc.,

### **Pump**

The pump creates the pressure necessary to force water through the components of the system including the fertilizer tank, filter unit, mainline, lateral and the emitters and drippers. Centrifugal pump operated by engines or electric motors are commonly used. The laterals may be designed to operate under pressures as low as 0.15 to 0.2 kg/cm<sup>2</sup> and as large as 1 to 1.75 kg/cm<sup>2</sup>. The water coming out of the emitters is almost at atmospheric pressure.

### **Chemical tank**

A tank may be provided at the head of the drip irrigation systems for applying fertilizers, herbicides and other chemicals in solution directly to the field along with irrigation water.

### **Filter**

It is an essential part of drip irrigation system. It prevents the blockage of pipes and drippers/emitters. The filter system consists of valves and a pressure gauge for regulation and control.

### **Emitters**

Drip nozzles commonly called drippers or emitters are provided at regular intervals on the laterals. They allow water to emit at very low rates usually in trickles. The amount of water dripping out of each emitters in a unit time will depend mainly upon the pressure and size of the opening. The discharge rate of emitters usually ranges from 2 to 10 litres per hour.

Micro-tubes are also used in a drip lateral. They are used mainly in the following ways (1) as emitters (2) as connectors, (3) as pressure regulators

### Advantages

1. Water saving - losses due to deep percolation, surface runoff and transmission are avoided. Evaporation losses occurring in sprinkler irrigation do not occur in drip irrigation.
2. Uniform water distribution
3. Application rates can be adjusted by using different size of drippers
4. Suitable for wide spaced row crops, particularly coconut and other horticultural tree crops
5. Soil erosion is reduced
6. Better weed control
7. Land saving
8. Less labour cost

### Disadvantages

1. High initial cost
  2. Drippers are susceptible to blockage
  3. Interferes with farm operations and movement of implements and machineries
  4. Frequent maintenance
  5. Trees grown may develop shallow confined root zones resulting in poor anchorage.
- LAYOUT OF SPRINKLER IRRIGATION SYSTEM
- The sprinkler (overhead or pressure) irrigation system conveys water to the field through pipes (aluminium or PVC) under pressure with a system of nozzles.
  - This system is designed to distribute the required depth of water uniformly, which is not possible in surface irrigation.

## Water Management including Micro Irrigation

- Water is applied at a rate less than the infiltration rate of the soil hence the runoff from irrigation is avoided.

**A sprinkler system usually consists of the following parts.**

1. A pumping unit
2. Debris removal equipment
3. Pressure gauge / water-meter
4. Pipelines (mains – sub-mains and laterals)
5. Couplers
6. Raiser pipes
7. Sprinklers
8. Other accessories such as valves, bends, plugs, etc.



### **Pumping unit**

A high speed centrifugal or turbine pump can be installed for operating the system for individual farm holdings. The pumping plants usually consist of a centrifugal or a turbine type pump, a driving unit, a suction line and a foot valve.

### **Pipe lines**

Pipelines are generally of two types. They are main and lateral. Main pipelines carry water from the pumping plant to many parts of the field. In some cases sub main lines are provided to take water from the mains to laterals. The lateral pipelines carry the water from the main or sub main pipe to the sprinklers. The pipelines may be either permanent, semi permanent or portable.

### **Couplers**

A coupler provides connection between two tubing and between tubing and fittings.

### **Sprinklers**

## Water Management including Micro Irrigation

Sprinklers may rotate or remain fixed. The rotating sprinklers can be adapted for a wide range of application rates and spacing. They are effective with pressure of about 10 to 70 m head at the sprinkler. Pressures ranging from 16-40 m head are considered the most practical for most farms. Fixed head sprinklers are commonly used to irrigate small lawns and gardens.

### **Other accessories / fittings**

1. Water meters - It is used to measure the volume of water delivered.
2. Pressure gauge - It is necessary to know whether the sprinkler is working with the desired pressure in order to deliver the water uniformly.
3. Bends, tees, reducers, elbows, hydrants, butterfly valves, end plugs and risers
4. Debris removal equipment: This is needed when water is obtained from streams, ponds, canals or other surface supplies. It helps to keep the sprinkler system clear of sand, weed seeds, leaves, sticks, moss and other trash that may otherwise plug the sprinklers.
5. Fertilizer applicators. These are available in various sizes. They inject fertilizers in liquid form to the sprinkler system at a desired rate.

### **Types of sprinkler system**

On the basis of arrangement for spraying irrigation water

1. Rotating head (or) revolving sprinkler system
2. Perforated pipe system

### **Based on the portability**

- 1. Portable system:** It has portable mainlines and laterals and a portable pumping unit
- 2. Semi portable system:** A semi portable system is similar to a fully portable system except that the location of the water source and pumping plant are fixed.
- 3. Semi permanent system:** A semi permanent system has portable lateral lines, permanent main lines and sub mains and a stationery water source and pumping plant.

## Water Management including Micro Irrigation

The mainlines and sub-mains are usually buried, with risers for nozzles located at suitable intervals.

**4. Solid set system:** A solid set system has enough laterals to eliminate their movement.

The laterals are placed in the field early in the crop season and remain for the season.

**5. Permanent system:** It consists of permanently laid mains, sub-mains and laterals and a stationary water source and pumping plant. Mains, sub-mains and laterals are usually buried below plough depth. Sprinklers are permanently located on each riser.

### Advantages

1. Water saving to an extent of 35-40% compared to surface irrigation methods.
2. Saving in fertilizers - even distribution and avoids wastage.
3. Suitable for undulating topography (sloppy lands)
4. Reduces erosion
5. Suitable for coarse textured soils (sandy soils)
6. Frost control - protect crops against frost and high temperature
7. Drainage problems eliminated
8. Saving in land
9. Fertilisers and other chemicals can be applied through irrigation water

### Disadvantages

1. High initial cost
2. Efficiency is affected by wind
3. Higher evaporation losses in spraying water
4. Not suitable for tall crops like sugarcane
5. Not suitable for heavy clay soils
6. Poor quality water can not be used (Sensitivity of crop to saline water and clogging of nozzles)

**Steps to be taken for reducing the salt deposits on leaves and fruits during sprinkler irrigation**

## Water Management including Micro Irrigation

- Irrigate at night
- Increase the speed of the sprinkler rotation
- Decrease the frequency of irrigation

Agrifair

## LEC. 18 & 19. METHODS OF IRRIGATION - SUITABILITY, ADVANTAGES AND LIMITATIONS

**Water application methods are grouped as:**

1. Flooding
2. Applying it beneath the soil surface
3. Spraying it under pressure
4. Applying in drops

### **Irrigation methods**

- I. Surface
- II. Sub-surface
- III. Pressurized irrigation

**Surface** is grouped as Border, Check basin and Furrow irrigations. Border is again classified in to two as straight and contour. Check basins may be of rectangular, contour or ring, whereas furrow irrigation is classified as deep furrow and corrugated furrows. These may be again straight or contour according to direction and leveled and graded as per their elevation

### **I. Surface irrigation**

#### **1. Border irrigation**

- The land is divided into number of long parallel strips called borders.
- These borders are separated by low ridges.
- The border strip has a uniform gentle slope in the direction of irrigation.
- Each strip is irrigated independently by turning the water in the upper end.
- The water spreads and flows down the strip in a sheet confined by the border ridges.

**Suitability :** To soils having moderately low to moderately high infiltration rates. It is not used in coarse sandy soils that have very high infiltration rates and also in heavy soils having very low infiltration rate. Suitable to irrigate all close growing crops like wheat, barley, fodder crops and legumes and not suitable for rice.

### Advantages

1. Border ridges can be constructed with simple farm implements like bullock drawn “A” frame ridger or bund former.
2. Labour requirement in irrigation is reduced as compared to conventional check basin method.
3. Uniform distribution of water and high water application efficiencies are possible.
4. Large irrigation streams can be efficiently used.
5. Adequate surface drainage is provided if outlets are available.

Width of border strip: It varies from 3-15 m

Border length

Slope	Soil	Length
0.25 - 0.60%	Sandy and sandy loam	60-120 m
0.20 - 0.40%	Medium loam soil	100-180 m
0.05 – 0.20%	Clay loam and clay soil	150-300 m

### 2. Check basin irrigation

- It is the most common method.
- Here the field is divided into smaller unit areas so that each has a nearly level surface.
- Bunds or ridges are constructed around the area forming basins within which the irrigation water can be controlled.
- The water applied to a desired depth can be retained until it infiltrates into the soil.
- The size of the basin varies from 10m<sup>2</sup> to 25 m<sup>2</sup> depending upon soil type , topography, stream size and crop.

### Adaptability

- ✓ Small gentle and uniform land slopes
- ✓ Soils having moderate to slow infiltration rates.
- ✓ Adapted to grain and fodder crops in heavy soils.
- ✓ Suitable to permeable soils.

## Water Management including Micro Irrigation

### Advantages

1. Check basins are useful when leaching is required to remove salts from the soil profile.
2. Rainfall can be conserved and soil erosion is reduced by retaining large part of rain
3. High water application and distribution efficiency.

### Limitations

1. The ridges interfere with the movement of implements.
2. More area occupied by ridges and field channels.
3. The method impedes surface drainage
4. Precise land grading and shaping are required
- 5. Labour requirement is higher.**
6. Not suitable for crops which are sensitive to wet soil conditions around the stem.

### Furrow irrigation

- ⇒ Used in the irrigation of row crops.
- ⇒ The furrows are formed between crop rows.
- ⇒ The dimension of furrows depend on the crop grown, equipment used and soil type.
- ⇒ Water is applied by small running streams in furrows between the crop rows.
- ⇒ Water infiltrates into soil and spreads laterally to wet the area between the furrows.
- ⇒ In heavy soils furrows can be used to dispose the excess water.

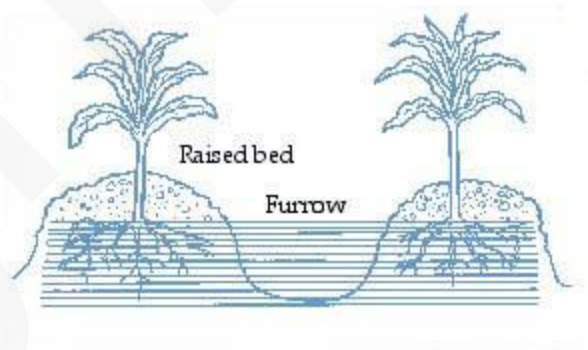

### Adaptability

1. Wide spaced row crops including vegetables.
2. Suitable for maize, sorghum, sugarcane, cotton, tobacco, groundnut, potatoes
3. Suitable to most soils except sand.

Agrifair

### Advantages

1. Water in furrows contacts only one half to one fifth of the land surface.
2. Labour requirement for land preparation and irrigation is reduced.
3. Compared to check basins there is less wastage of land in field ditches.



### Types of furrow irrigation

Based on alignment of furrows

- : 1. Straight furrows
- 2. Contour furrows

Based on size and spacing : 1. Deep furrows 2. Corrugations

### Based on irrigation:

- All furrow irrigation:** Water is applied evenly in all the furrows and are called furrow system or uniform furrow system.
- Alternate furrow irrigation:** It is not an irrigation layout but a technique for water saving. Water is applied in alternate furrows for eg. During first irrigation if the even

numbers of furrows are irrigated, during next irrigation, the odd number of furrows will be irrigated.

- C. **Skip furrow irrigation:** They are normally adopted during the period of water scarcity and to accommodate intercrops. In the skip furrow irrigation, a set of furrows are completely skipped out from irrigation permanently. The skipped furrow will be utilized for



raising intercrop. The system ensures water saving of 30-35 per cent. By this method, the available water is economically used without much field reduction.

- D. **Surge irrigation:** Surge irrigation is the application of water in to the furrows intermittently in a series of relatively short ON and OFF times of irrigation cycle. It has been found that intermittent application of water reduces the infiltration tare over surges thereby the water front advances quickly. Hence, reduced net irrigation water requirement. This also results in more uniform soil moisture distribution and storage in the crop root zone compared to continuous flow. The irrigation efficiency is in between 85 and 90%.

## II. Sub-surface irrigation

- ◆ In subsurface irrigation, water is applied beneath the ground by creating and maintaining an artificial water table at some depth, usually 30-75 cm below the ground surface.
- ◆ Moisture moves upwards towards the land surface through capillary action
- ◆ Water is applied through underground field trenches laid 15-30 m apart.

## Water Management including Micro Irrigation

- ◆ Open ditches are preferred because they are relatively cheaper and suitable to all types of soil.
- ◆ The irrigation water should be of good quality to prevent soil salinity.

### Advantages

1. Minimum water requirement for raising crops
2. Minimum evaporation and deep percolation losses
3. No wastage of land
7. No interference to movement of farm machinery
8. Cultivation operations can be carried out without concern for the irrigation period.

### Disadvantages

1. Requires a special combination of natural conditions.
2. There is danger of water logging
3. Possibility of choking of the pipes lay underground.
4. High cost.

### DRIP IRRIGATION SYSTEM

- Drip or trickle irrigation is one of the latest methods of irrigation.
- It is suitable for water scarcity and salt affected soils.
- Water is applied in the root zone of the crop

Standard water quality test needed for design and operation of drip irrigation system.

*(Major inorganic salts, hardeners, suspended solids, total dissolved solids, biological oxygen demand, chemical oxygen demand, organic, and organic matter, micro-organisms, iron, dissolved oxygen, H<sub>2</sub>S, iron bacteria, sulphur reducing bacteria etc have to be tested)*

### Components

- ◆ A drip irrigation system consists of a pump or overhead tank, main line, sub-mains, laterals and emitters.

## Water Management including Micro Irrigation

- ◆ The mainline delivers water to the sub-mains and the sub-mains into the laterals.
- ◆ The emitters which are attached to the laterals distribute water for irrigation.
- ◆ The mains, sub-mains and laterals are usually made of black PVC (poly vinyl chloride) tubing. The emitters are also made of PVC material
- ◆ The other components include regulator, filters, valves, water meter, fertilizer application components, etc.,

### **Pump**

The pump creates the pressure necessary to force water through the components of the system including the fertilizer tank, filter unit, mainline, lateral and the emitters and drippers. Centrifugal pump operated by engines or electric motors are commonly used. The laterals may be designed to operate under pressures as low as 0.15 to 0.2 kg/cm<sup>2</sup> and as large as 1 to 1.75 kg/cm<sup>2</sup>. The water coming out of the emitters is almost at atmospheric pressure.

### **Chemical tank**

A tank may be provided at the head of the drip irrigation systems for applying fertilizers, herbicides and other chemicals in solution directly to the field along with irrigation water.

### **Filter**

It is an essential part of drip irrigation system. It prevents the blockage of pipes and drippers/emitters. The filter system consists of valves and a pressure gauge for regulation and control.

### **Emitters**

Drip nozzles commonly called drippers or emitters are provided at regular intervals on the laterals. They allow water to emit at very low rates usually in trickles. The amount of water dripping out of each emitters in a unit time will depend mainly upon the pressure and size of the opening. The discharge rate of emitters usually ranges from 2 to 10 litres per hour.

Micro-tubes are also used in a drip lateral. They are used mainly in the following ways (1) as emitters (2) as connectors, (3) as pressure regulators

### Advantages

1. Water saving - losses due to deep percolation, surface runoff and transmission are avoided. Evaporation losses occurring in sprinkler irrigation do not occur in drip irrigation.
2. Uniform water distribution
3. Application rates can be adjusted by using different size of drippers
4. Suitable for wide spaced row crops, particularly coconut and other horticultural tree crops
5. Soil erosion is reduced
6. Better weed control
7. Land saving
8. Less labour cost

### Disadvantages

1. High initial cost
  2. Drippers are susceptible to blockage
  3. Interferes with farm operations and movement of implements and machineries
  4. Frequent maintenance
  5. Trees grown may develop shallow confined root zones resulting in poor anchorage.
- LAYOUT OF SPRINKLER IRRIGATION SYSTEM
- The sprinkler (overhead or pressure) irrigation system conveys water to the field through pipes (aluminium or PVC) under pressure with a system of nozzles.
  - This system is designed to distribute the required depth of water uniformly, which is not possible in surface irrigation.

## Water Management including Micro Irrigation

- Water is applied at a rate less than the infiltration rate of the soil hence the runoff from irrigation is avoided.

**A sprinkler system usually consists of the following parts.**

1. A pumping unit
2. Debris removal equipment
3. Pressure gauge / water-meter
4. Pipelines (mains – sub-mains and laterals)
5. Couplers
6. Raiser pipes
7. Sprinklers
8. Other accessories such as valves, bends, plugs, etc.



### **Pumping unit**

A high speed centrifugal or turbine pump can be installed for operating the system for individual farm holdings. The pumping plants usually consist of a centrifugal or a turbine type pump, a driving unit, a suction line and a foot valve.

### **Pipe lines**

Pipelines are generally of two types. They are main and lateral. Main pipelines carry water from the pumping plant to many parts of the field. In some cases sub main lines are provided to take water from the mains to laterals. The lateral pipelines carry the water from the main or sub main pipe to the sprinklers. The pipelines may be either permanent, semi permanent or portable.

### **Couplers**

A coupler provides connection between two tubing and between tubing and fittings.

### **Sprinklers**

## Water Management including Micro Irrigation

Sprinklers may rotate or remain fixed. The rotating sprinklers can be adapted for a wide range of application rates and spacing. They are effective with pressure of about 10 to 70 m head at the sprinkler. Pressures ranging from 16-40 m head are considered the most practical for most farms. Fixed head sprinklers are commonly used to irrigate small lawns and gardens.

### **Other accessories / fittings**

1. Water meters - It is used to measure the volume of water delivered.
2. Pressure gauge - It is necessary to know whether the sprinkler is working with the desired pressure in order to deliver the water uniformly.
3. Bends, tees, reducers, elbows, hydrants, butterfly valves, end plugs and risers
4. Debris removal equipment: This is needed when water is obtained from streams, ponds, canals or other surface supplies. It helps to keep the sprinkler system clear of sand, weed seeds, leaves, sticks, moss and other trash that may otherwise plug the sprinklers.
5. Fertilizer applicators. These are available in various sizes. They inject fertilizers in liquid form to the sprinkler system at a desired rate.

### **Types of sprinkler system**

On the basis of arrangement for spraying irrigation water

1. Rotating head (or) revolving sprinkler system
2. Perforated pipe system

### **Based on the portability**

- 1. Portable system:** It has portable mainlines and laterals and a portable pumping unit
- 2. Semi portable system:** A semi portable system is similar to a fully portable system except that the location of the water source and pumping plant are fixed.
- 3. Semi permanent system:** A semi permanent system has portable lateral lines, permanent main lines and sub mains and a stationery water source and pumping plant.

## Water Management including Micro Irrigation

The mainlines and sub-mains are usually buried, with risers for nozzles located at suitable intervals.

**4. Solid set system:** A solid set system has enough laterals to eliminate their movement.

The laterals are placed in the field early in the crop season and remain for the season.

**5. Permanent system:** It consists of permanently laid mains, sub-mains and laterals and a stationary water source and pumping plant. Mains, sub-mains and laterals are usually buried below plough depth. Sprinklers are permanently located on each riser.

### Advantages

1. Water saving to an extent of 35-40% compared to surface irrigation methods.
2. Saving in fertilizers - even distribution and avoids wastage.
3. Suitable for undulating topography (sloppy lands)
4. Reduces erosion
5. Suitable for coarse textured soils (sandy soils)
6. Frost control - protect crops against frost and high temperature
7. Drainage problems eliminated
8. Saving in land
9. Fertilisers and other chemicals can be applied through irrigation water

### Disadvantages

1. High initial cost
2. Efficiency is affected by wind
3. Higher evaporation losses in spraying water
4. Not suitable for tall crops like sugarcane
5. Not suitable for heavy clay soils
6. Poor quality water can not be used (Sensitivity of crop to saline water and clogging of nozzles)

**Steps to be taken for reducing the salt deposits on leaves and fruits during sprinkler irrigation**

## Water Management including Micro Irrigation

- Irrigate at night
- Increase the speed of the sprinkler rotation
- Decrease the frequency of irrigation

Agrifair

\*\*\*\*\* 😊 \*\*\*\*\*

**Visit for Other Agriculture books, News,  
Recruitment, Information, and Events at**

**[WWW.AGRIFAIR.IN](http://WWW.AGRIFAIR.IN)**

Give FeedBack & Suggestion at [info@Agrifair.in](mailto:info@Agrifair.in)

**DISCLAIMER:**

The information on this website does not warrant or assume any legal liability or responsibility for the accuracy, completeness or usefulness of the courseware contents.

The contents are provided free for noncommercial purpose such as teaching, training, research, extension and self learning.

\*\*\*\*\* 😊 \*\*\*\*\*